



ROTISSERIE



Introducing 2011 Vermont Castings Signature Series Grills

PREMIUM CRAFTSMANSHIP.
PRECISION COOKING.

MAKE A STATEMENT WITH PREMIUM DESIGN

When you fire up a Vermont Castings grill, you're getting more than just power. You're getting a premium product designed to deliver precise results and make every outdoor meal an event. From the latest convenience features to stunning style, our Signature Series grills have it all. No matter what you're cooking, you'll make a statement with a beautiful, new Signature Series grill.



SIGNATURE QUALITY ON EVERY GRILL

The Signature FlavorSeal System lets you enjoy more consistent temperatures and even heat distribution, locking in flavors and juices for amazing results.

INTRODUCING THE SIGNATURE FLAVORSEAL SYSTEM

MORE EVEN COOKING



As experts in the field of cast iron, Vermont Castings delivers the finest quality **CAST IRON, PORCELAIN-COATED GRATES**. Cast iron helps to redistribute heat to create more even cooking, consistent temperatures and restaurant-style sear marks for beautiful presentation. They're rounded on one side for cooking juicy foods, like burgers and steaks, and flat on the other side to easily remove tender foods like seafood. Plus, the reversible grates are durable and easy to clean.

CONVECTION-STYLE COOKING



The **EXCLUSIVE CAST IRON END CAPS** and **EXTRA DEEP FIREBOX** help maintain heat to lock in flavors and juices while keeping food amazingly moist. The smooth surface simplifies cleanup.

EXCLUSIVE

PREVENT FLARE-UPS



For healthy cooking, the **SIGNATURE SEAR PLATES** are designed to redirect grease and juices away from the flames — distributing heat evenly across the entire cooking surface for optimal temperature control.



SOPHISTICATED PERFORMANCE, CONVENIENCE AND STYLE

PRECISION CONTROL, YEAR ROUND

The ideal rate of power for the most even grilling is between 95 and 110 BTUs per square inch. All of our Signature Series grills fall near this range, with the 501 Series delivering an optimal 104 BTUs of power per square inch. So year round, our grills will heat up faster and give you more control over doneness levels. You'll be able to cook that medium rare steak to perfection, even in colder climates.

SAFE AND EASY IGNITION

Available on all our Signature Series grills, the **EasyFlame Ignition System** uses a single source to ignite every burner, ensuring that each one lights safely and consistently, avoiding ignition flare-ups. Unlike most other grills, you can light any burner the first time for ultimate convenience.



TOP-GRADE STAINLESS STEEL CONSTRUCTION

Made with superior quality 304 True Stainless Steel, our Signature Series grills* resist rust better than grills made with lower grades of stainless steel. Plus, they offer a sleek, modern look.

EASY-TO-SEE CONTROLS

The beautiful LED display brightly illuminates the controls on every Signature Series grill, making it easy to grill at any time of the day or night.

*Excluding 310 model.



THE POWER TO COOK A GREATER VARIETY OF FOODS

All of our Signature Series grills deliver powerful performance. Our grills offer a BTU range of up to 102,500 with the ability to use four different cooking methods: searing, baking, turning (rotisserie) and smoking. That way, you can achieve the results you want for any kind of food, from seared sirloin to tenderly grilled vegetables.

ENOUGH ROOM TO GRILL 36 BURGERS AT ONCE**

With up to a total of 990 square inches of cooking space on the 501 Series, you can fit more at once on this grill! Plus, with that much room, you can sear steaks on one side of the grill while grilling vegetables at low temps on the other side. Perfect for family gatherings or parties!

**Based on approximately 4" diameter patties.

MANY WAYS TO GRILL

SEAR IT — For steaks, meats or vegetables, the direct grilling method is ideal. The sear plates on Vermont Castings grills are specially designed to prevent flare-ups.

BAKE IT — For results similar to baking, use the indirect cooking method, lighting one side of the grill while placing food on the other side. The exclusive cast iron end caps help maintain the heat for optimal results.

TURN IT — Seal in juices and flavor with rotisserie cooking. Our infrared rotisserie burner offers slow roasting for convenient, hands-free cooking of roasts, turkey and more.

SMOKE IT — For that unforgettable smoky flavor, use our smoker box and the indirect cooking method to add flavor to fish, steak, ribs, chicken and more!

501



501 Series Built-In
Shown with optional french doors

501 SIGNATURE SERIES

With features you won't find on competitively priced models, this five-burner grill offers the best combination of style, power and value. You'll have the versatility to cook everything with restaurant-style performance. Also available as a built-in model, you can customize the look to your own personal taste. Family and friends will love gathering around this stunning addition to your outdoor décor.

Featuring:

- Signature FlavorSeal System
- 5 Burners
- Up to 102,500 BTUs
- 990 sq. in. Total Cooking Area
- 104 BTUs per sq. in.
- Rotisserie Burner & Kit
- 304 True Stainless Steel Construction, including Firebox
- 15,000 BTU Side Burner
- Grill Light
- Condiment Shelves, Side Shelves and Towel Bars (freestanding model only)

401



401 Series in Black Enamel

401 SIGNATURE SERIES

Four burners and a total of 69,000 BTUs deliver power that caters to your every need, whether you're serving up burgers for a crowd or a nice steak dinner for two. Plus, convenience features like the LED flex light and included rotisserie kit make it easy to cook anything on the grill day or night.

Featuring:

- Signature FlavorSeal System
- 4 Burners
- Up to 69,000 BTUs
- 753 sq. in. Total Cooking Area
- 110 BTUs per sq. in.
- Rotisserie Burner & Kit
- 304 True Stainless Steel Construction
- Grill Light
- Condiment Shelves, Side Shelves and Towel Bar

301 & 310



310 SERIES



301 SERIES

**Rated #1
by a leading
consumer
magazine***

*Based on 2010 mid-size grill category, 300 Series.



301 Series Built-In
Shown with optional french doors

301 & 310 SIGNATURE SERIES

Our two three-burner models offer the convenience of our EasyFlame Ignition, LED controls and powerful performance. Plus, the 301 Series provides True Stainless Steel construction and convenience shelves. And, for an extra infusion of style, it's available as a built-in model so you can customize the look to your own personal taste!

301 Featuring:

- Signature FlavorSeal System
- 3 Burners
- Up to 55,500 BTUs
- 673 sq. in. Total Cooking Area
- 92 BTUs per sq. in.
- Rotisserie Burner
- 304 True Stainless Steel Construction
- Condiment Shelves, Side Shelves and Towel Bar (freestanding model only)

310 Featuring:

- Signature FlavorSeal System
- 3 Burners
- Up to 40,500 BTUs
- 673 sq. in. Total Cooking Area
- 92 BTUs per sq. in.

CHOOSE THE PERFECT SIGNATURE SERIES GRILL FOR YOU!



Model

310

301

Available Colors

Black Enamel

Black Enamel
Stainless Steel
Also available in a built-in style

PERFORMANCE

Signature FlavorSeal System	Yes	Yes
EasyFlame Ignition System	Yes	Yes
Main Burners	3 (304 True Stainless Steel)	3 (304 True Stainless Steel)
Main BTUs	40,500	40,500
Rotisserie Burner	—	Yes, 15,000 BTUs
Side Burner	Optional	Optional
Total BTUs	40,500	55,500
Total Cooking Area	673 sq. in.	673 sq. in.
BTUs per Sq. In.	92	92

QUALITY AND STYLE

304 True Stainless Steel Construction	—	Yes
Porcelain-coated Cast Iron Grates	Yes	Yes
304 True Stainless Steel Sear Plates	Yes	Yes
Firebox Construction	Porcelain enameled steel	Porcelain enameled steel

CONVENIENCE

Rotisserie Kit	Optional	Optional
Grill Light	Optional	Optional
Towel Bars	—	Yes
Condiment Shelves	—	Yes (304 True Stainless Steel, freestanding model only)
Side Shelves	Yes, painted black	Yes (304 True Stainless Steel, freestanding model only)
Front Doors	Removable, painted black	French (304 True Stainless Steel standard with freestanding; built-in optional)
Smoker Box	Optional	Yes



Model

401

501

Available Colors

Black Enamel
Stainless Steel

Stainless Steel
Also available in a built-in style

PERFORMANCE

Signature FlavorSeal System	Yes	Yes
EasyFlame Ignition System	Yes	Yes
Main Burners	4 (304 True Stainless Steel)	5 (304 True Stainless Steel)
Main BTUs	54,000	67,500
Rotisserie Burner	Yes, 15,000 BTUs	Yes, 20,000 BTUs
Side Burner	Optional	Yes, 15,000 BTUs
Total BTUs	69,000	102,500
Total Cooking Area	753 sq. in.	990 sq. in.
BTUs per Sq. In.	110	104

QUALITY AND STYLE

304 True Stainless Steel Construction	Yes	Yes
Porcelain-coated Cast Iron Grates	Yes	Yes
304 True Stainless Steel Sear Plates	Yes	Yes
Firebox Construction	Porcelain enameled steel	304 True Stainless Steel

CONVENIENCE

Rotisserie Kit	Yes	Yes
Grill Light	Yes	Yes
Towel Bars	Yes	Yes
Condiment Shelves	Yes (304 True Stainless Steel)	Yes (304 True Stainless Steel, freestanding model only)
Side Shelves	Yes (304 True Stainless Steel)	Yes (304 True Stainless Steel, freestanding model only)
Front Doors	French (304 True Stainless Steel)	French (304 True Stainless Steel standard with freestanding; built-in optional)
Smoker Box	Yes	Yes

GRILL DIMENSIONS

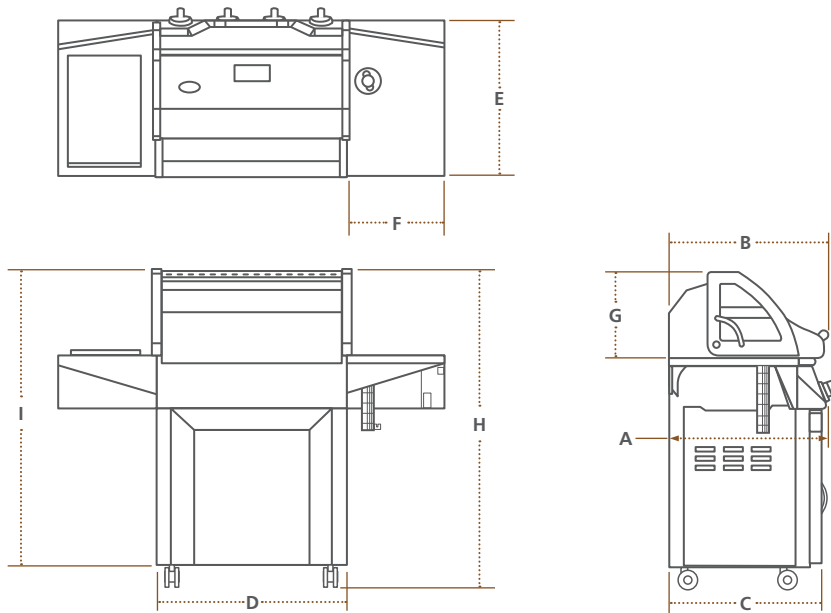

Model	310	301	401	501
A. Depth (measured from front to back at top of cart)	24.8"	24.8"	24.8"	24.8"
B. Depth (measured from front of lid to back including handle)	23.9"	23.9"	23.9"	23.9"
C. Depth (measured from front to back at bottom of cart)	23.4"	23.4"	23.4"	23.4"
D. Width (measured from side to side at bottom of cart)	26.4"	26.4"	29.4"	38.4"
E. Depth (measured from front to back of side shelf)	24.6"	24.6"	24.6"	24.6"
F. Side Shelf Width	15.1"	15.1"	15.1"	15.1"
G. Lid Height	13.4"	13.4"	13.4"	13.4"
H. Grill Height (including casters)	49.4"	49.4"	49.4"	49.4"
I. Grill Height (without casters)	47.8"	47.8"	47.8"	47.8"

Model	301 Built-In*	501 Built-In*
Firebox Depth	24"	24"
Firebox Height	9.375"	9.375"
Firebox Width	31.5"	43.5"
Sideburner Depth	18.25"	18.25"
Sideburner Height	10"	10"
Sideburner Width	12.625"	12.625"
Door Height	18.75"	18.75"
Door Width	28.75"	28.75"

*Built-in dimensions provided are framing dimensions to non-combustible materials. Please see owner's manual for exact installation measurements and instructions.

CUSTOMIZE WITH ACCESSORIES

Be sure to check out our available accessories. From stovetop burners to searing burners, you'll be able to customize your grill to suit your needs.



15,000 BTU Side Burner

For those who love to cook everything outdoors, this side burner provides stove-top cooking right there at the grill. That way, you'll reduce trips to and from the kitchen, enhancing your grilling experience.



Infrared Sear Burner

This accessory uses infrared radiation to heat and sear meat at high temperatures to lock in flavors and juices. That way, you can enjoy the versatility of two grilling technologies in one, while also cooking multiple foods at different temperatures.



Griddle

Breakfast, anyone? The griddle accessory makes it easy to cook foods like pancakes or bacon.



Rotisserie Kit

Available as an accessory for our 310 and 301 Series, the Rotisserie Kit includes the rotisserie motor and hexagon rod, specially designed to easily handle foods like large turkeys. The counter balance on the rotisserie keeps the rotation consistent to improve cooking performance.



Grill Cover

For premium protection, this special cover is designed to protect the grill from the elements, year round. Ventilation allows moisture to escape, which helps prevent mildew.



4-Piece Tool Set

Made with the same fine craftsmanship as our grills, this tool set gives you everything you need in one convenient package.



Your Vermont Castings Dealer:

To avoid personal injury or property damage, the product described by this brochure must be installed, operated and maintained in strict compliance with the instructions packaged with the product and all applicable building or fire codes. Contact local building or fire officials about restrictions and installation inspection requirements. All photographs and drawings on this brochure are for illustrative purposes only and are not intended for, nor should they be used as a substitute for, the instructions packaged with the unit. Appearance and specifications of the product are subject to change without notice. © 2010 Monessen Hearth Systems Co. 11042 05/11