

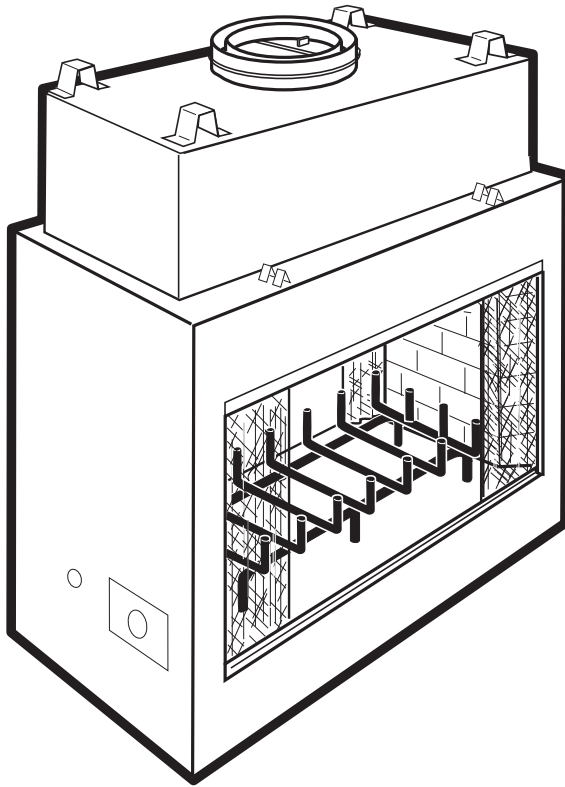

STR36 Designer Woodburning Fireplace

Homeowner's Installation and Operating Manual



NATIONAL FIREPLACE INSTITUTE
NFI
CERTIFIED
www.nficertified.org

We recommend that our woodburning hearth products be installed and serviced by professionals who are certified in the U.S. by the National Fireplace Institute® (NFI) as NFI Woodburning Specialists or who are certified in Canada by Wood Energy Technical Training (WETT).

Wood Energy Technical Training
www.wettinc.ca

DO NOT DISCARD THIS MANUAL: Retain for future use.

Safety Information

PLEASE READ THIS MANUAL BEFORE INSTALLING AND USING FIREPLACE.

IMPORTANT: Read all instructions and warnings carefully before starting installation. Failure to follow these instructions may result in a possible fire hazard and will void the warranty.

Description

The STR36 fireplaces are multi-side solid fuel, woodburning fireplaces. These are radiant models only and include a preinstalled outside air kit.

Precautions

MHSC and component parts have been highly tested and will operate safely when installed in accordance with instructions provided in this manual. Carefully read and understand all instructions **before** beginning installation.

If you notice any damage to fireplace or component parts, immediately report damage to your MHSC dealer.

Only use MHSC components or the warranty will be voided and a fire hazard may be created.

MHSC warranty will be voided by and MHSC disclaims any responsibility for the following actions:

- **Installation by any other than a qualified installer, preferably NFI or WETT (Canada) certified.**
- **Installation of any damaged fireplace or chimney component;**
- **Modification of fireplace, chimney assembly or any component parts thereof; (except for chase flashings as detailed in the Chimney Top installation instructions).**
- **Installation other than as instructed by MHSC; or**
- **Installation and/or use of any component part not manufactured or approved by MHSC in combination or assembly with a MHSC fireplace system, notwithstanding any independent testing laboratory or other third party approval of such component parts or accessory.**

Any such action may possibly cause a fire hazard.

Consult local building codes to ensure that you are in compliance **before** installing the fireplace.

Fireplaces must be vented to the out-of-doors.

Do not obstruct or modify air inlets/outlets in any manner.

Do not install combustible materials on any of the black fireplace surround.

Burn only solid wood fuel or gas logs.

Do not install a solid fuel burning insert or other products not specified for use with this fireplace.

Proposition 65 Warning: Fuels used in gas, wood-burning or oil fired appliances, and the products of combustion of such fuels, contain chemicals known to the State of California to cause cancer, birth defects and other reproductive harm.

California Health & Safety Code Sec. 25249.6

WARNING: Check with your electronics manufacturer before installing a television or other electronic device above this fireplace.

Drafts

The fireplace should not be located in areas that create drafts (ie: frequently opened doors and central heating air inlets/outlets) that hamper the normal flow of air into the fire.

Gas Logs

If you plan to install a gas log, the gas line should be installed **before** framing the fireplace. The gas line must be installed by a certified gas line installer.

**STR36
Listed**

**UL 127 / ULC-S610
Standard for Factory Built Fireplaces**

Table of Contents

Safety Information	2
Specifications and Framing	3
Parts Identification	4
Chimney Requirements	6
Planning Information	7
Installation	8
Replacement Parts	20
Accessories	22

STR36 Fireplace Dimensions

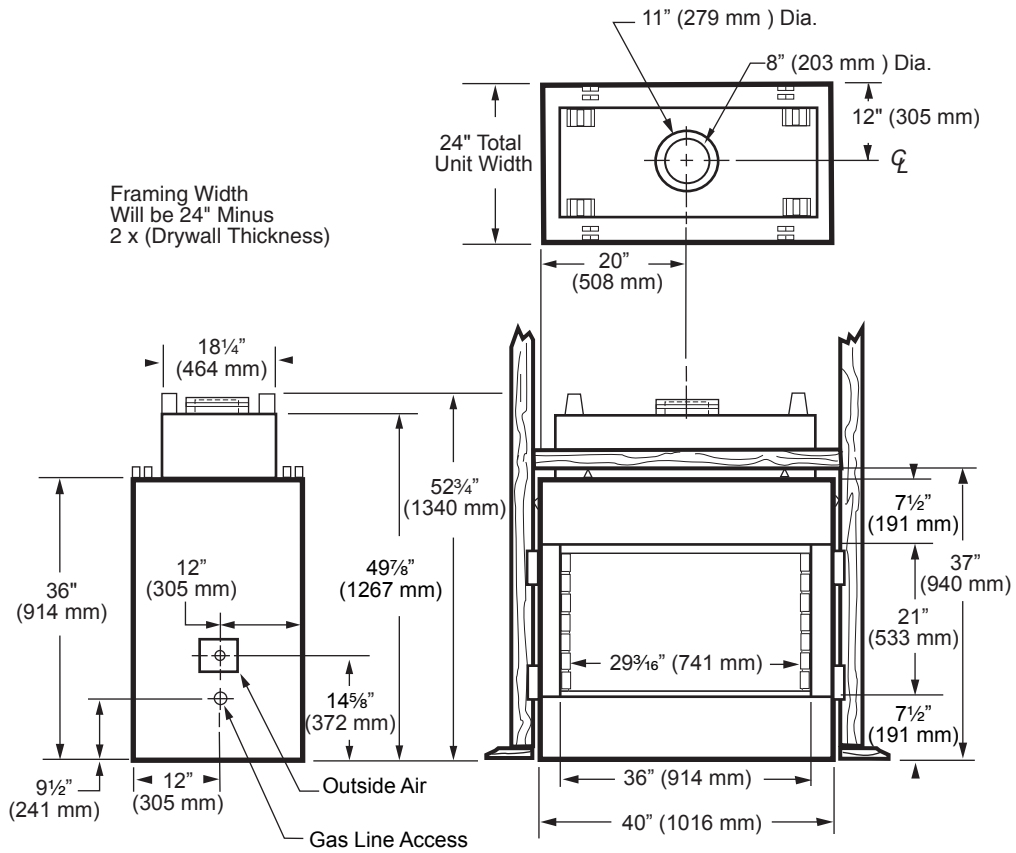

Fig. 1 STR36 specifications and framing.

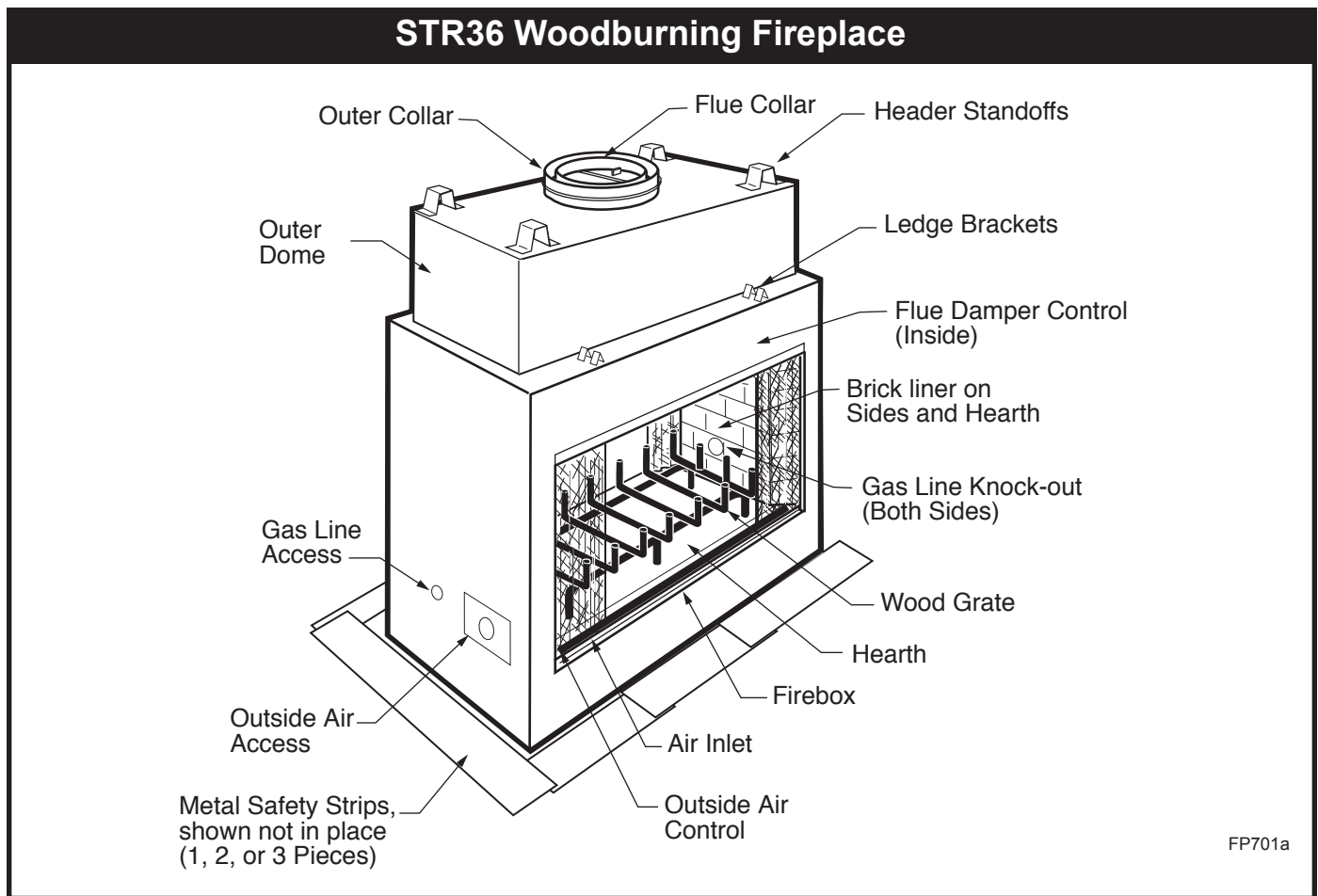

Fig. 3 STR36 Parts Identification.

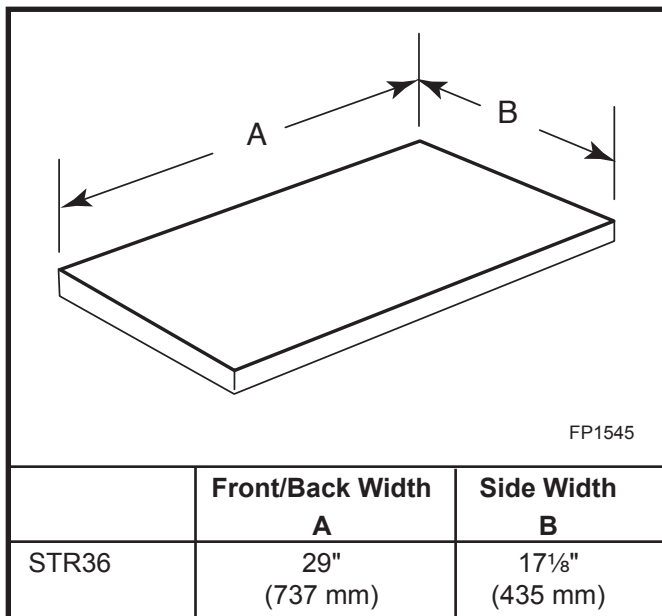
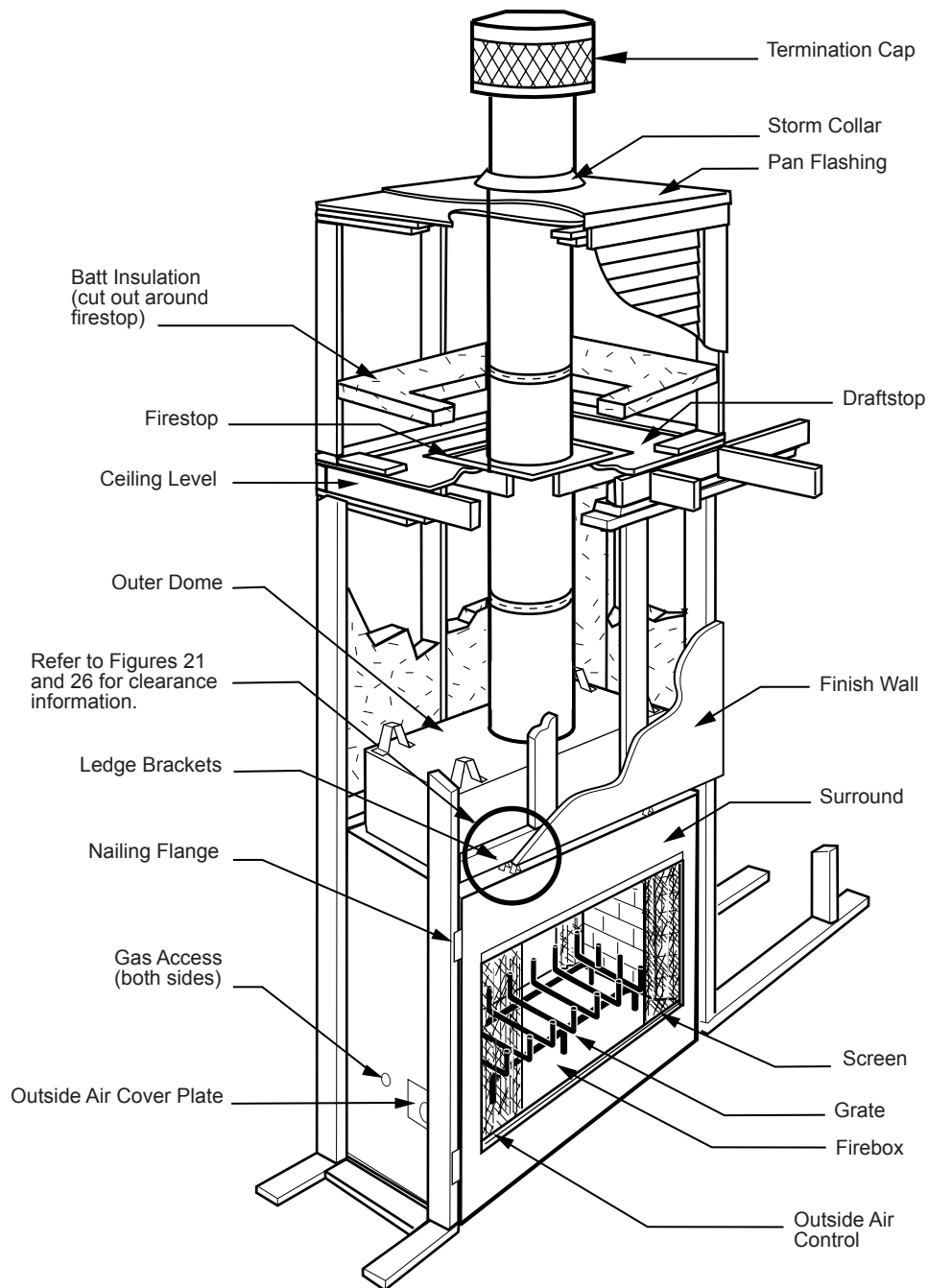

Fig. 3a Hearth dimensions.

Chase Installation

Insulation methods shown are optional for cold climate, not a requirement for unit operation.



FP704

Fig. 4 Fireplace and chase parts identification.

Chimney Requirements - Offset Installations

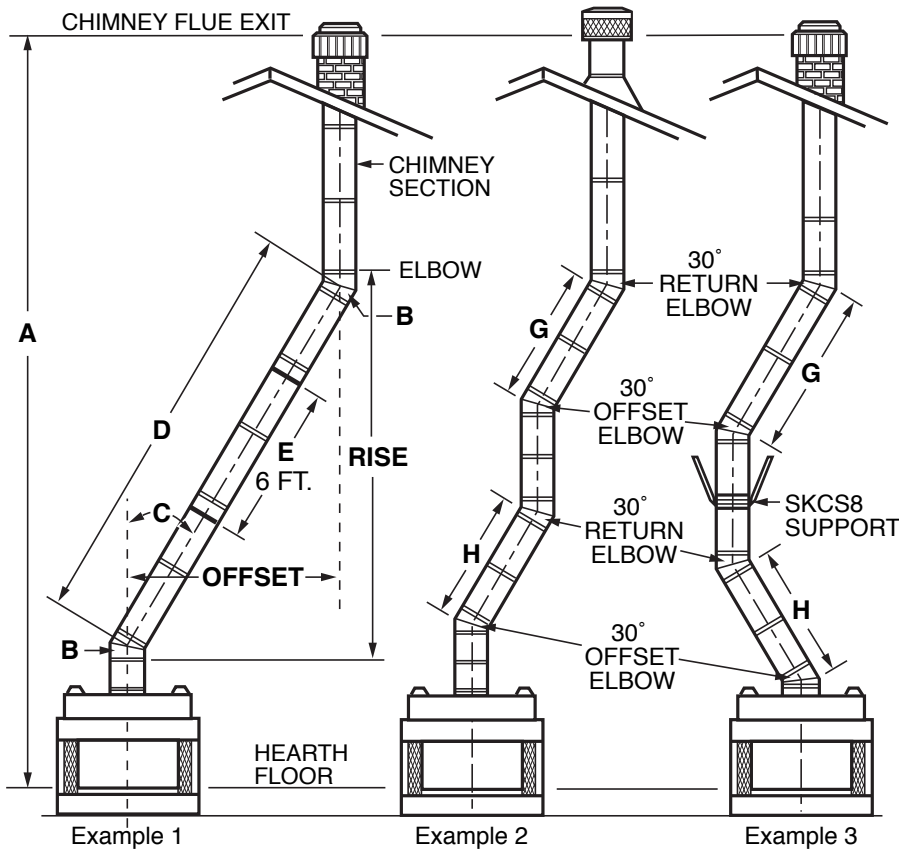

Notes: G + H cannot exceed 20 feet.
 Air Space Clearances:
 SK8 (2-wall) = 1 1/2"

FP720

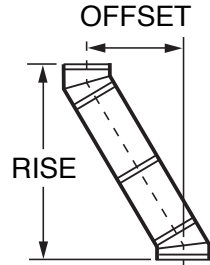

FP282

30° Elbow Offsets

1'	1 1/2'	3'	4'	Chimney Support	Offset	Rise
0	0	0	0	0	3"	11"
1	0	0	0	0	8 1/4"	20"
0	1	0	0	0	11 1/4"	25 1/4"
2	0	0	0	0	13 1/2"	29 1/4"
1	1	0	0	0	16 1/2"	34 1/4"
0	0	1	0	0	20 1/4"	40 3/4"
2	1	0	0	0	21 3/4"	43 1/2"
0	0	0	1	0	26 1/4"	51 1/4"
0	1	1	0	0	28 1/2"	55 1/4"
1	0	0	1	0	31 1/2"	60 1/4"
0	1	0	1	0	34 1/2"	65 1/2"
0	0	2	0	0	37 1/2"	70 3/4"
1	1	0	1	1	41 1/2"	77 3/4"
0	0	1	1	1	45"	83 3/4"
0	1	2	0	1	47 1/4"	87 1/2"
0	0	0	2	1	51"	94"
0	1	1	1	1	53 1/4"	98"
0	0	3	0	1	56 1/4"	103 1/4"
0	1	0	2	1	59 1/4"	108 1/2"
0	0	2	1	1	62 1/4"	113 1/2"
0	1	3	0	1	64 1/2"	117 1/2"
0	0	1	2	1	68 1/4"	124"
0	1	2	1	1	70 1/2"	128"
0	0	0	3	1	74 1/4"	134 1/2"
0	1	1	2	2	78"	140 3/4"
0	0	3	1	2	81"	146"
0	1	0	3	2	84"	151 1/4"
0	0	2	2	2	87"	156 1/2"
0	1	3	1	2	89 1/4"	160 1/4"
0	0	1	3	2	93"	166 3/4"
0	1	2	2	2	95 1/4"	170 3/4"
0	0	0	4	2	99 1/4"	177 3/4"
0	1	1	3	2	101 1/4"	181 3/4"
0	0	3	2	2	104 1/4"	186 1/4"
0	1	0	4	2	107 1/4"	191 1/2"
0	0	2	3	2	110 1/4"	196 3/4"
0	1	3	2	3	114"	203 1/4"
0	0	1	4	3	117 3/4"	209 3/4"
0	1	2	3	3	120"	213 1/2"
0	0	0	5	3	123 3/4"	220"

Illustration Key

The following safety rules apply to offset installations (letters correspond with illustration above):

A. Height of the chimney is measured from the hearth to the chimney exit.

	STR36
Maximum:	90'0"
Minimum:	
Without Elbows	15'6"
With 2 Elbows*	17'6"
With 4 Elbows*	21' 0"

B. Do not use more than 4 elbows per chimney.

Attach the straps of the return (top) elbow to a structural framing member.

The offset (first) elbow of any pair does not have straps.

C. The chimney cannot be more than 30° (45° in Canada) from the vertical plane in any installation*.

D. The maximum length of the angled run of the **total** chimney system is 20 feet. (G plus H cannot exceed 20 feet.)

E. A chimney support (Models TCS8A) is required every 6 feet of angled run of chimney. Chimney supports are required for every 30 feet and 60 feet of vertical chimney height above the hearth.

Determine the offset distance of your chimney arrangement from the centerline of the fireplace to the centerline of the chimney where it is to pass through the first ceiling.

NOTE: This offset distance may not be your full offset distance. See Examples 2 and 3.

* In Canada, two (2) SK845 are allowed.

Fig. 5 Chimney system requirements.

Planning Information

Preplanning an installation is very important to ensure safety and to save time and money. An installer must predetermine where a fireplace will be set and how the chimney system will be run.

NOTE: The STR36 model uses MHSC SK8 (2-wall) chimney systems.

Mounting the Fireplace

A fireplace may only be mounted on the following surfaces:

1. A flat combustible surface.
2. A raised wooden platform.
3. A concrete block or other solid object placed beneath each of the four (4) corners of the fireplace.

The fireplace **must** be spaced 1/2" (13 mm) from a combustible back wall and 1/2" (13 mm) from a combustible side wall or support. (Page 14, Fig. 20)

Planning the Chimney Run

Determine how the chimney will be run, length of run and chimney components required to complete the job. (Fig. 6) **Never** install a chimney below minimum heights.

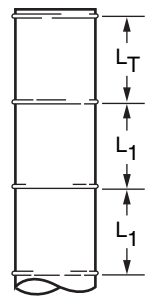
	MODEL SK & 2 WALL CHIMNEY	TOTAL LENGTH (L _T)	INSTALLED LENGTH (L _I)
	SK81	11½"	10½"
	SK818	17½"	16½"
	SK83	35½"	34½"
	SK84	47½"	46½"

FP705

Fig. 6 Installed lengths of chimney sections.

In planning a chimney system, it is important to know:

1. The height of a chimney is measured from the hearth to the exit point on the termination.
2. A chimney cannot be offset more than 30° from a vertical plane.
3. A chimney may run straight up or it may be necessary to offset it to avoid obstructions.
4. The maximum length of an angled run (total chimney system) is 20' (6 m).
5. No more than 2 offsets (4 total 30° elbows in U.S./or 2 total 45° elbows in Canada) per fireplace may be used.
6. A guy wire stabilizer is required for chimneys extending more than 6' (1.8 m) above a roof line.

The Ten Foot Rule

Major U.S. building codes specify a minimum chimney height above the roof top. The "Ten Foot Rule" is a fire safety rule and not a draft rule. To ensure proper draft, it is recommended that you always meet or exceed the "Ten Foot Rule," especially when installing a termination on a high pitch roof. (Fig. 7)

The key points of the "Ten Foot Rule" are:

1. If the horizontal distance from the chimney to the peak of the roof is 10' (3 m) or less, the top of the chimney must be at least 2' (610 mm) above the peak of the roof, but never less than 3' (914 mm) in height above the highest point where it passes through the roof.
2. If a horizontal distance from the chimney to the peak of the roof is more than 10' (3 m), a chimney height reference point is established on the surface of the roof a distance of 10' (3 m) from the chimney in a horizontal plane. The top of the chimney must be at least 2' (610 mm) above the reference point, but never less than 3' (914 mm) in height above the highest point where it passes through the roof.

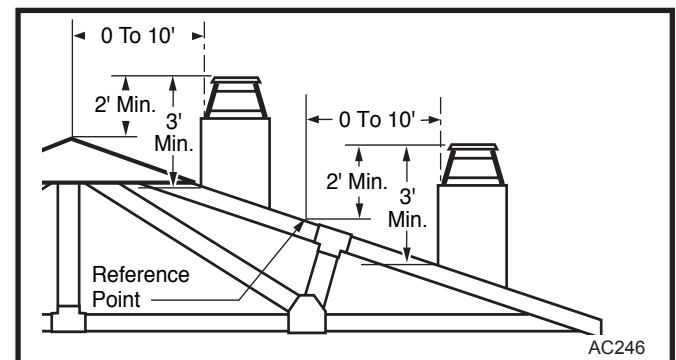

Fig. 7 Ten Foot Rule illustration.

Chimney Supports

The chimney system is supported by the fireplace for vertical chimney heights less than 20' (6 m) above the hearth. Chimney supports are required if the vertical height exceeds 20' (6 m). Locate chimney supports at ceiling holes or other structural framing at 20' (6 m) heights. Spacing between chimney supports **must not** exceed 20' (6 m). Use Chimney Support Model SKCS8 for SK8 chimney. (**NOTE: the chimney support can not be mounted directly to the fireplace.**) Support provided by elbow straps fulfills the support requirement only if they are spaced as previously described. (A chimney support is 2½" (64 mm) long when installed.)

Angled chimney runs require a support every 6' (1.8 m) in addition to the elbow straps. Chimney supports are used for this function. (Fig. 9)

Chase Installation

A chase is a vertical box-like structure which encloses the fireplace and/or chimney. Chases are typically built on the outside of the house with fireplace opening cut into the outer wall of a room. (Page 5, Fig. 4)

If you need help in determining fireplace location or how the chimney system should be run, contact your MHSC dealer for assistance.

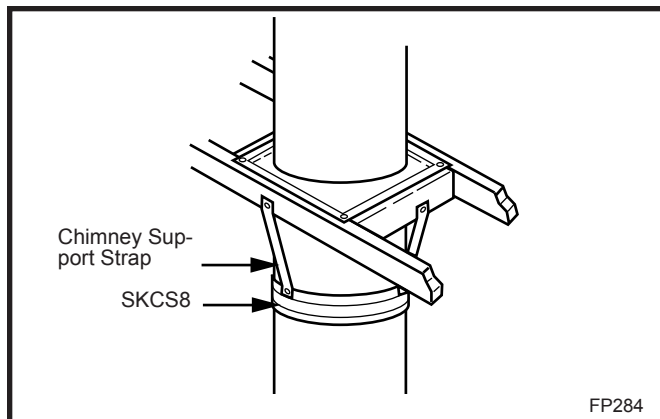

Fig. 8 Chimney support installation

Installation

Insulating Fireplace Enclosure for Cold Climates

If you live in a cold climate, it is not required but **highly recommended** that you insulate fireplace enclosure to eliminate cold air penetration as much as possible.

Insulate base of fireplace with a non-combustible insulation rated for a minimum of 300°F. Insulating is **very important** for outside wall installations over a concrete slab. If fireplace is installed on a platform, insulation should be placed on top of the platform **before** fireplace is set. (Fig. 9)

When a fireplace is installed in a chase or on a outside wall, enclosure should be treated like any outside wall in a home. Insulation should be installed on the inside wall as well as the outside wall(s). In a chase, it is also a good idea to install a firestop at the first ceiling level above the fireplace and enclose the chase with sheeting material. Insulation may then be installed above sheeting material to assure the space around the fireplace is totally protected. (Fig. 4)

When installing the chimney, **DO NOT** caulk between outer pipe and firestop. It is vital that some air be allowed to flow through this very thin gap.

CAUTION: WHEN INSTALLING A FIREPLACE IN AN INSULATED ENCLOSURE, BE SURE ALL REQUIRED AIR SPACES ARE MAINTAINED. (Page 14, Fig. 20)

Framing

Framing can be constructed before or after the fireplace is set in place, however, most installers build the frame before setting the fireplace.

Frame fireplace with 2 x 4 lumber or heavier materials. Refer to framing dimensions in Figures 1, 2, 3 or 4 for basic fireplace specifications. Headers and support studs must be turned on end as illustrated on Page 5, Figure 4.

NOTE: Framing should be positioned to accommodate wall covering and fireplace facing material. **Maintain 1/2" (13 mm) air space between the outer dome and any combustible framing materials that may be supported by the ledge brackets. Refer to Figures 20 and 26 for details.**

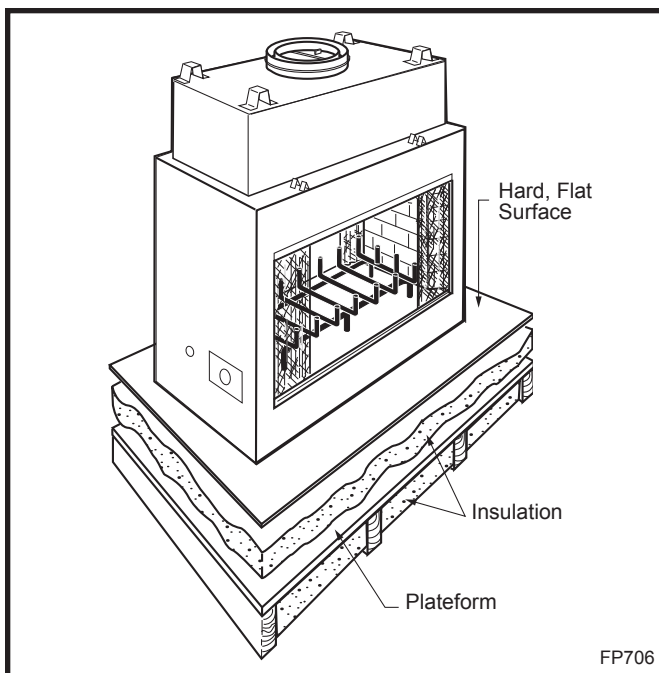

Fig. 9 Insulating between platform and fireplace.

Chimney Set-up

Since you have already preplanned the chimney run, you should know exactly how the installation is to be accomplished — how much pipe is required, the number of elbows, if any, and type of termination to be used.

CAUTION: REPORT TO YOUR DEALERS ANY PARTS DAMAGED IN SHIPMENT, SPECIFICALLY CHECK THE END CONNECTION OF CHIMNEY SECTIONS AND ELBOWS.

NOTE: The STR36 model uses MHSC SK8 (2-wall) chimney systems.

Straight-Up Chimney Installation

To locate the centerline of the flue put the fireplace in final position and place a plumb bob from the ceiling to the center of the fireplace flue collar. Mark this spot on the ceiling. Draw a line through that mark to either side of the firebox and indicate dimension X to locate the side wall framing. (Fig. 10) Be sure to observe clearance requirements for side and parallel combustible walls as noted in Page 16, Figure 23.

Offset Installation

In order to clear an obstruction, it may be necessary to offset chimney from vertical. This is accomplished by using MHSC elbows. Use the *30° Offset Elbow* table on Page 6 to determine proper offset and parts required.

Each offset requires two (2) elbows. The second elbow is equipped with support straps. It is very important to install the second elbow in each offset as close to the ceiling or support as possible so that the elbow straps can be secured to framing members to help support the weight of the chimney.

Determine offset distance of your chimney arrangement from centerline of fireplace to centerline of chimney where it is to pass through ceiling.

Locate center point of the chimney on ceiling as though a straight up chimney arrangement is to be used. Measure your offset dimension from the chimney center point on the ceiling.

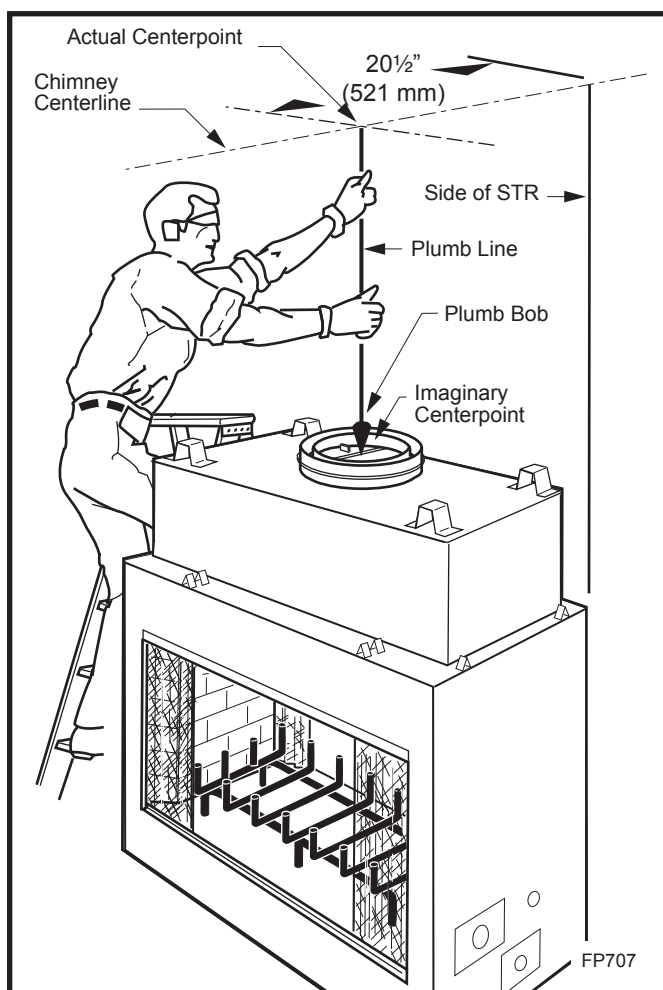

Fig. 10 Locate centerline of chimney with plumb line.

Ceiling Chimney Hole/ Possible Obstructions

The size of the hole in ceiling will vary with the angle at which the chimney passes through ceiling.

Drive a nail up through ceiling at marked chimney center point. Go to floor above and see where hole will be cut. Check to see where existing ceiling joists and other possible obstructions are located...i.e. wiring, plumbing etc... If necessary, re-position chimney and/or fireplace to avoid obstructions.

Cutting the Hole

Cover fireplace collar opening and cut proper sized chimney hole in chimney. The SK8 pipe allows you to run pipe through a typical 16" on center joist without cutting joists.

Framing the Ceiling Hole

Frame the ceiling chimney hole as shown in Figure 12. It is good practice to use framing lumber that is the same size as the ceiling joists; this is a requirement at attic level.

The following table gives firestop spacer model numbers:

Size of Chimney 8" Flue "SK" Series	Angle of Chimney at Ceiling	
	Vertical	30°
SKFS2A 14½" x 14½" (368 x 368 mm)	SKFS6A 14½" x 25½" (368 x 648 mm)	

Fig. 11 Ceiling chimney hole sizes necessary for installing firestop spacer.

The **inside dimension** of the frame **must be** the same as the hole size selected from Figure 12 in order to provide the required air space (1½" (38 mm) with SK8 between the outside diameter of the chimney and the edges of the framed ceiling hole.

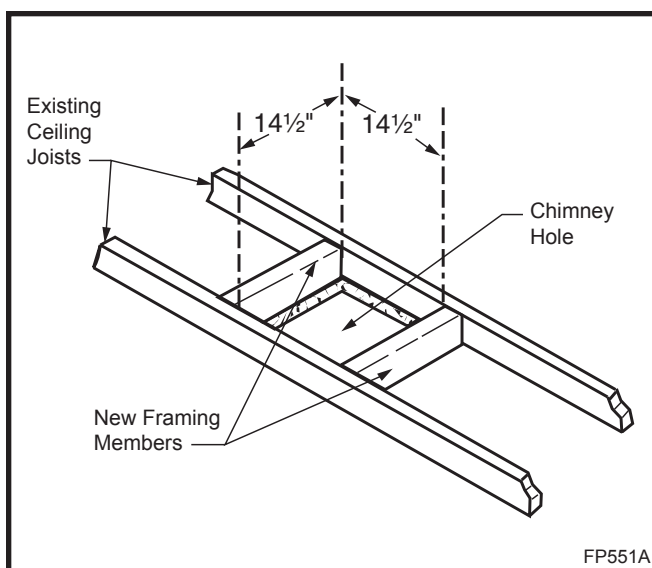

Fig. 12 Typical frame for ceiling chimney hole.

Positioning, Safety Strips, Securing the Fireplace

Slide fireplace into position.

Lift the fireplace front slightly and slide the metal safety strips under front bottom edge about 1½" (38 mm), allowing the remainder to extend in front of firebox. Overlap strips at least ½" (13 mm) to provide a positive joint. (Flat safety strips are packed with fireplace.) (Fig. 13)

Safety strips are used to ensure that any combustible materials in front of the fireplace are protected even though a noncombustible hearth extension is required.

If fireplace is to be elevated above the floor, a "Z" shaped metal safety strip must be fabricated and used to protect combustible surfaces in front of the fireplace. This "Z" shaped safety strip is not provided but must be fabricated of metal with each horizontal leg at least 1½" (38 mm) wide and equal in length to the metals strips provided with the fireplace.

NOTE: Safety strips are not required over non-combustible floors where all supports at the base of the fireplace are noncombustible.

Eight (8) nailing flanges are supplied with the fireplace (found on the fireplace hearth). To level the box and secure it firmly in place, remove the nailing flanges from the hearth and install at the sides of the fireplace as shown in Figure 14.

Outside Air Kit

An outside air kit damper is installed in STR36 Fireplaces. If desired, or if local codes mandate the use of an air kit, then an AK-MST is required to complete the installation (from air kit to the outdoors). If the outside air kit is to be used, the AK-MST Air Termination Kit **MUST** be installed **BEFORE** the fireplace is enclosed. Refer to the AK-MST instructions for field installation. The outside air kit control is located in the lower left hand side of the fireplace behind the screen panel. (Fig. 15) To operate, simply lift up to close or push down to open .

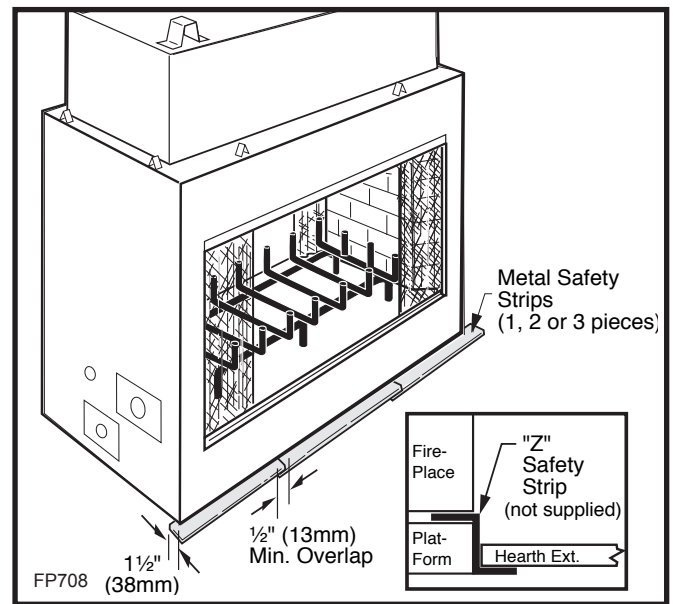

Fig. 13 Safety strip installation.

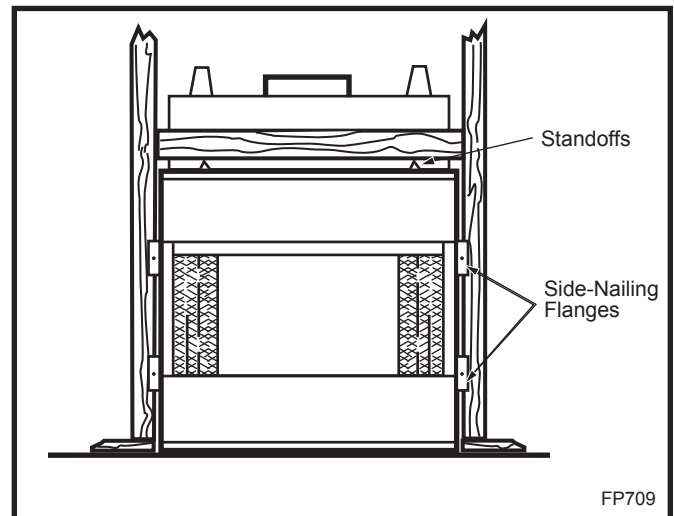

Fig. 14 Fasten fireplace in position.

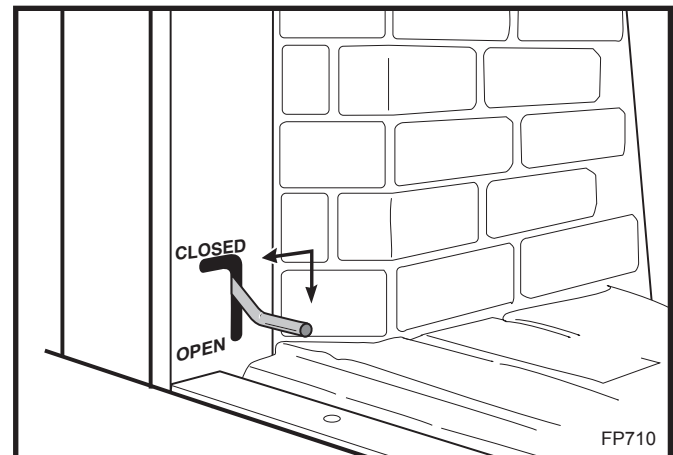

Fig. 15 Outside air operation.

Installing the Chimney System

Start by attaching the first chimney section to the collar on top of the fireplace.

Install the pipe as pictured in Figure 16. When you get a good lock, you will hear the pipe clearly snap together. Once sections are snap-locked in place, it is extremely difficult to get them apart. **Make sure the pipe is firmly snapped and locked together as each pipe section is mounted.**

When installing elbows, only outer pipe will snap-lock. Middle pipes simply slide into position. Be sure to always attach straps on upper elbow to a structural framing member. (Fig. 17)

Continue installing the pipe as required until pipe is installed up through the ceiling. At this point, you must install a firestop spacer. Refer to Figure 18 for appropriate spacer orientation.

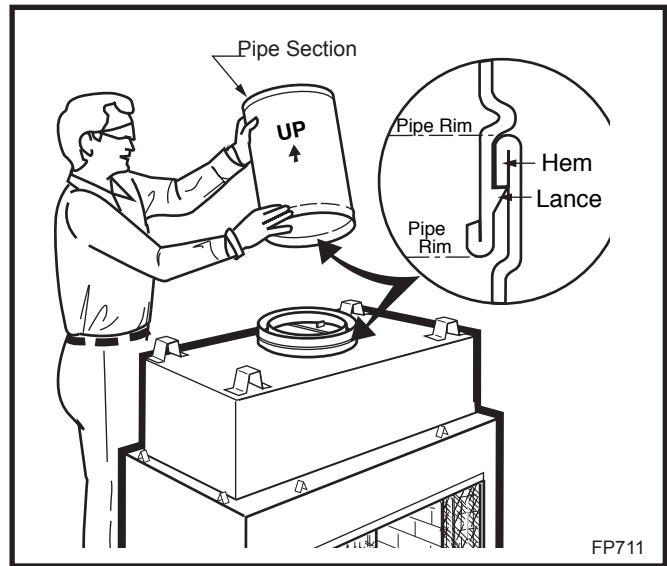

Fig. 16 Install pipe, listening for the snap-lock to fasten.

Installing the Firestop Spacer in the Ceiling Hole

A firestop spacer is used to keep pipe spaced properly and required for safety.

Nail the firestop spacer (at each corner) to the framing members of the ceiling hole. **NOTE:** A firestop spacer is not required at the roof.

Hole sizes listed in Figure 12 for angled firestop spacers provide minimum required air space to chimney pipe for ceiling thickness up to 8" (203 mm). When combined thickness of ceiling material, ceiling joists and flooring material exceeds 8" (203 mm), adjustments must be made in framing to assure that minimum air spaces to chimney are maintained.

Proper Firestop Spacer Installation

Figure 18 shows different installation procedures for both an area that is an attic and an area that is not an attic.

If the area above the ceiling is not an attic, position the firestop spacer with the flange on the ceiling side and the angled portion extending up into the hole.

If the area above the ceiling is an attic, position the firestop spacer with the flange on the top of the framed hole and the angled portion extending down into the hole.

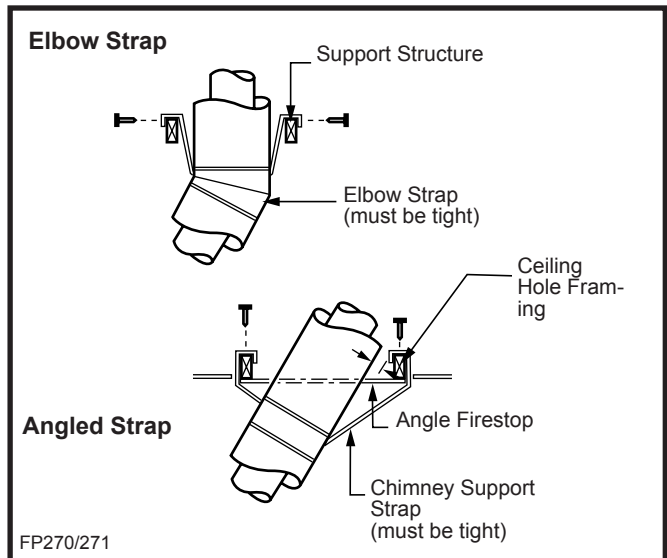

Fig. 17 Attach straps to a structural framing member.

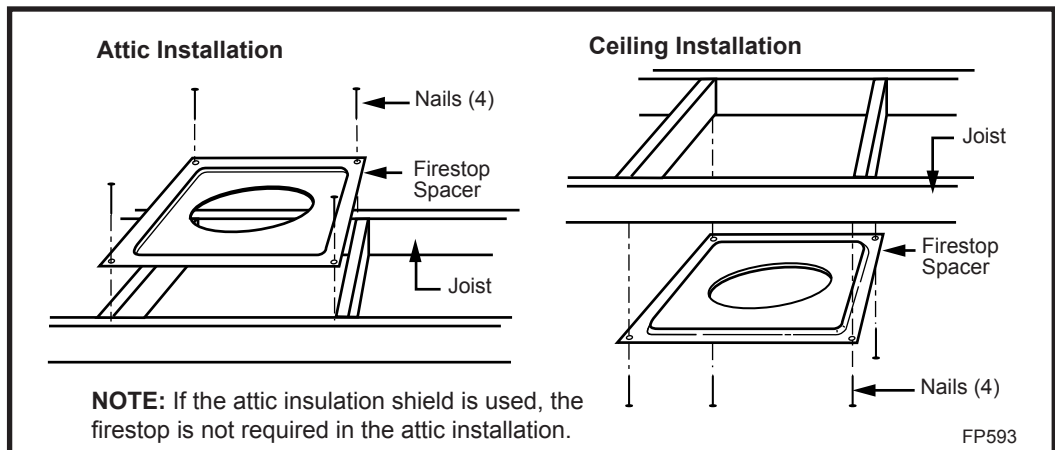

Fig. 18 Installing firestop spacer.

Firestop spacers are not available for nor are they required on vertical walls.

DO NOT put any sealant around the area where the outer pipe slides through the firestop spacer. If you seal this area, it may cause a fire hazard.

Canadian Requirements for Insulation Shield

In Canada, an attic insulation shield is required to prevent attic insulation from contacting the chimney section. **NOTE:** If the attic insulation shield is used, the firestop is not required in the attic installation. Framing dimensions for the chimney hole should measure 14½" x 14½" (368 x 368 mm). (An attic shield **MUST** be installed on top of attic joists (above the floor level). (Fig. 19)

NOTE: In the U.S., it is a good idea, although not always required, to install an attic insulation shield where blown-in insulation is planned to be used in the attic.

Install the attic insulation shield with the flanges on its base extending down into the framing hole. Nail each corner of attic insulation shield to the framing members of the ceiling hole using 8d nails. Attic shields are not required at the roof.

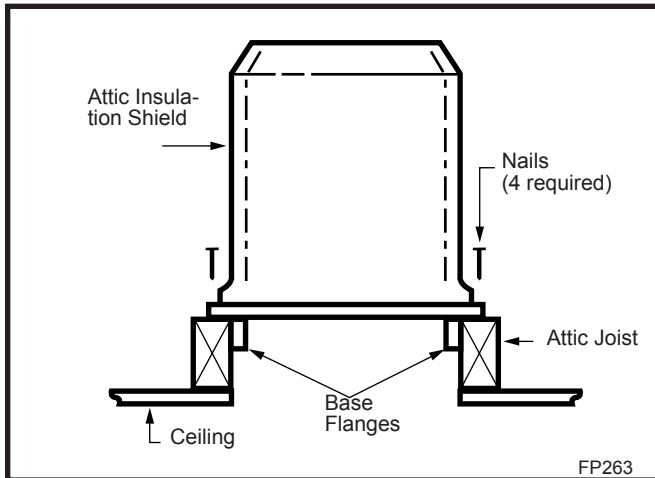

Fig. 19 Attic shield installation (Canadian requirement).

Continue Installing Pipe to Complete Run

Continue attaching pipe sections to complete system to next level always being careful that the pipe is firmly snapped locked in place before proceeding to next pipe section.

Chimney Supports

If chimney supports are required, they are installed the same as elbows. Nail chimney support straps to adjacent structural framing, as shown on Figure 8, Page 8. Bend straps as necessary and make sure they are secure so they will support the weight of the chimney. A chimney support is 2½" (64 mm) long when installed.

Consider this dimension when determining how many straight chimney sections are needed.

NOTE: Chimney supports are generally used in long runs in a chase installation. **A chimney support cannot be mounted directly to the fireplace.**

Additional Ceilings

If you encounter additional ceilings, repeat same steps required for first ceiling installation. Refer to firestop illustration on Page 12, Figure 18.

Penetrating the Roof

Run pipe to roofline. Since chimney system must be vented to the out-of-doors, you **must** use an approved termination.

If a chase is used, refer to the installation manual provided with the termination cap.

Locate Chimney Centerpoint on Roof

Use same procedure detailed in locating centerpoint of the flue system.

Drive a nail up through roof at the centerpoint. This will determine center point on outside of the roof.

Cut and Frame Roof Hole

Size of roof hole varies with the type of chimney termination installed. Refer to installation instructions provided with the chimney termination to find correct size of roof hole.

There must be an air space (1½" (38 mm) with SK8 between outermost portion of chimney sections and any adjacent combustible surfaces. (Fig. 20) (Combustible surfaces include burnable materials such as: ceiling members, joists, flooring, combustible insulation and roof structures.)

WARNING: DO NOT PACK REQUIRED AIR SPACES WITH INSULATION OR OTHER MATERIALS.

Mark an outline of the roof hole around the center of the point nail. **NOTE:** Hole dimensions given in the chimney top installation instructions are **horizontal** dimensions; therefore, the hole size must be marked on the roof accordingly.

Cover the opening of the installed chimney so debris cannot get into the system.

Cut and frame the hole. It is good practice to use framing lumber that is the same size as the rafters. Install the frame securely because the chimney top and flashing anchored to the frame must be able to withstand heavy winds.

Install Remainder of Chimney Sections

Since you have already preplanned the height of your termination according to the *Ten Foot Rule*, continue to install pipe to the predetermined height.

Check the chimney top installation instructions for details on how high above the roof top the chimney sections (all pipes) should extend.

Installing Top Housing or Termination

Follow the installation instructions provided with the chimney termination you have selected.

Installing Chimney In a Chase

Refer to Page 5, Figure 4 for an illustration of a typical chase installation.

CAUTION: Treatment of firestop spacers and construction of chase may vary with type of building. These instructions are not a substitute for local building codes. You **must** check your local building codes to determine specific requirements for your city or state. **NOTE:** Other building materials may be required in addition to Firestop Spacers.

Finishing

CAUTION: All joints between the finished wall and the fireplace surround (top/sides) must be sealed with non-combustible material to prevent cold air leakage into the room. Only noncombustible material may be applied to the facing of the fireplace surround. (Black painted area) (Fig. 20)

Finish Wall

Finish the wall with material of your choice. **Do not install a combustible mantel shelf less than 12" (305 mm) above the front opening. Do not install a mantel face plate less than 6" (159 mm) from top of fireplace opening. (Fig. 21)** If a combustible material is used below a flat mantel shelf, consult your local building codes for minimum clearance from top of fireplace opening to bottom of mantel shelf.

NOTE: No side wall protection is required for fireplaces installed at 45° to two (2) side walls (corner installation). Adjacent combustible side walls that are within 16" (406 mm) of fireplace opening must be protected with an MHSC Wall Shield Model SP40 or a specifically built wall shield described in Figure 20 & 24.

Often a decorative surround or vertical portion of the mantel is desired. If this is constructed of any combustible material, it must be within the safe zone indicated in Figure 24.

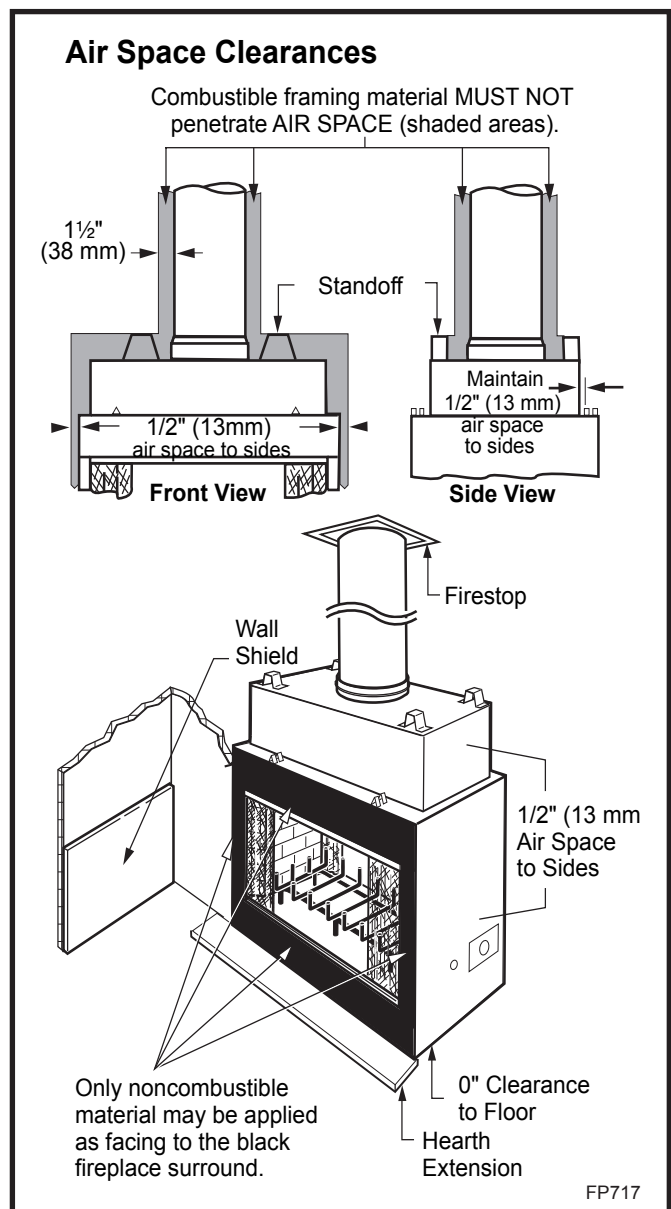

Fig. 20 Minimum clearances to combustibles.

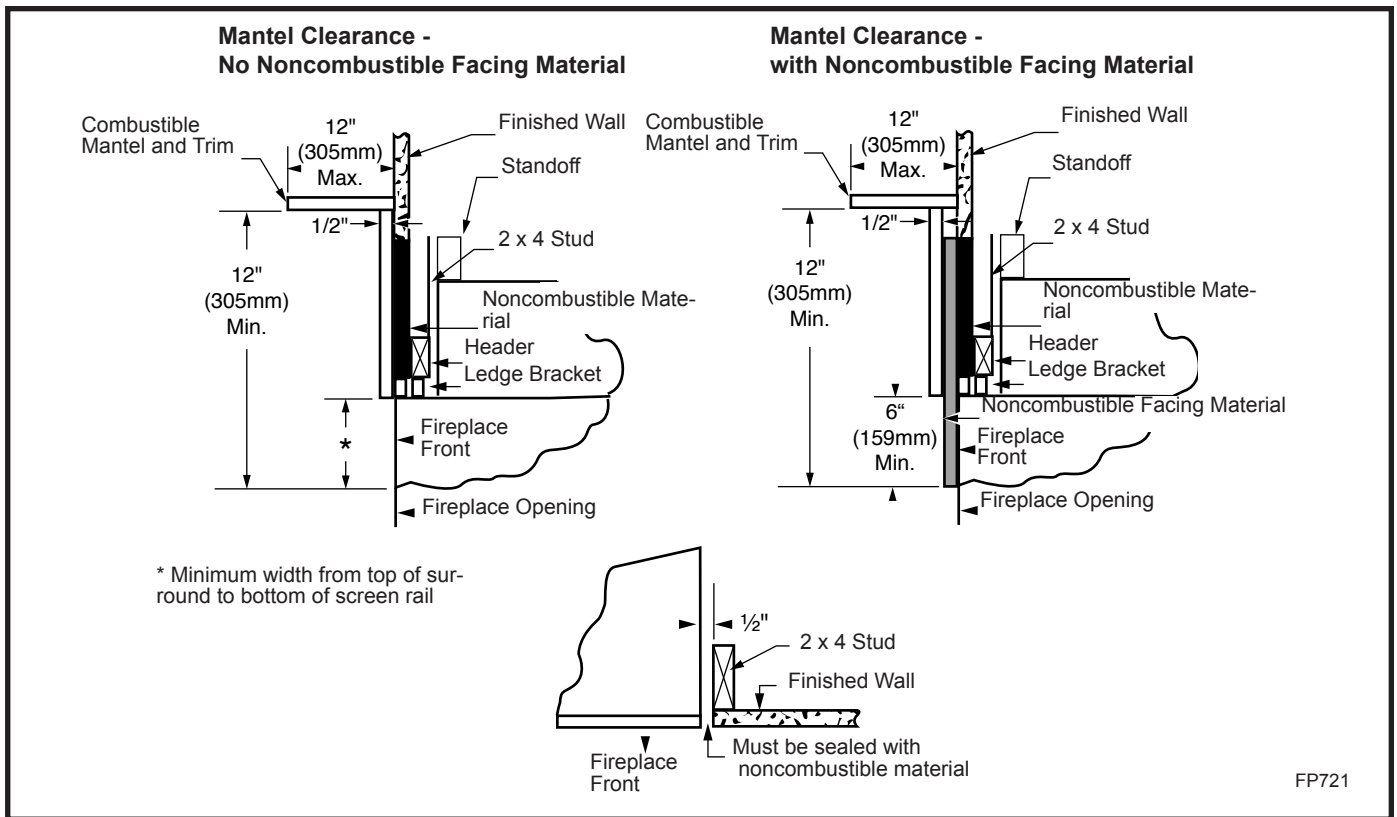

Fig. 21 Fireplace surround flush with finished wall.

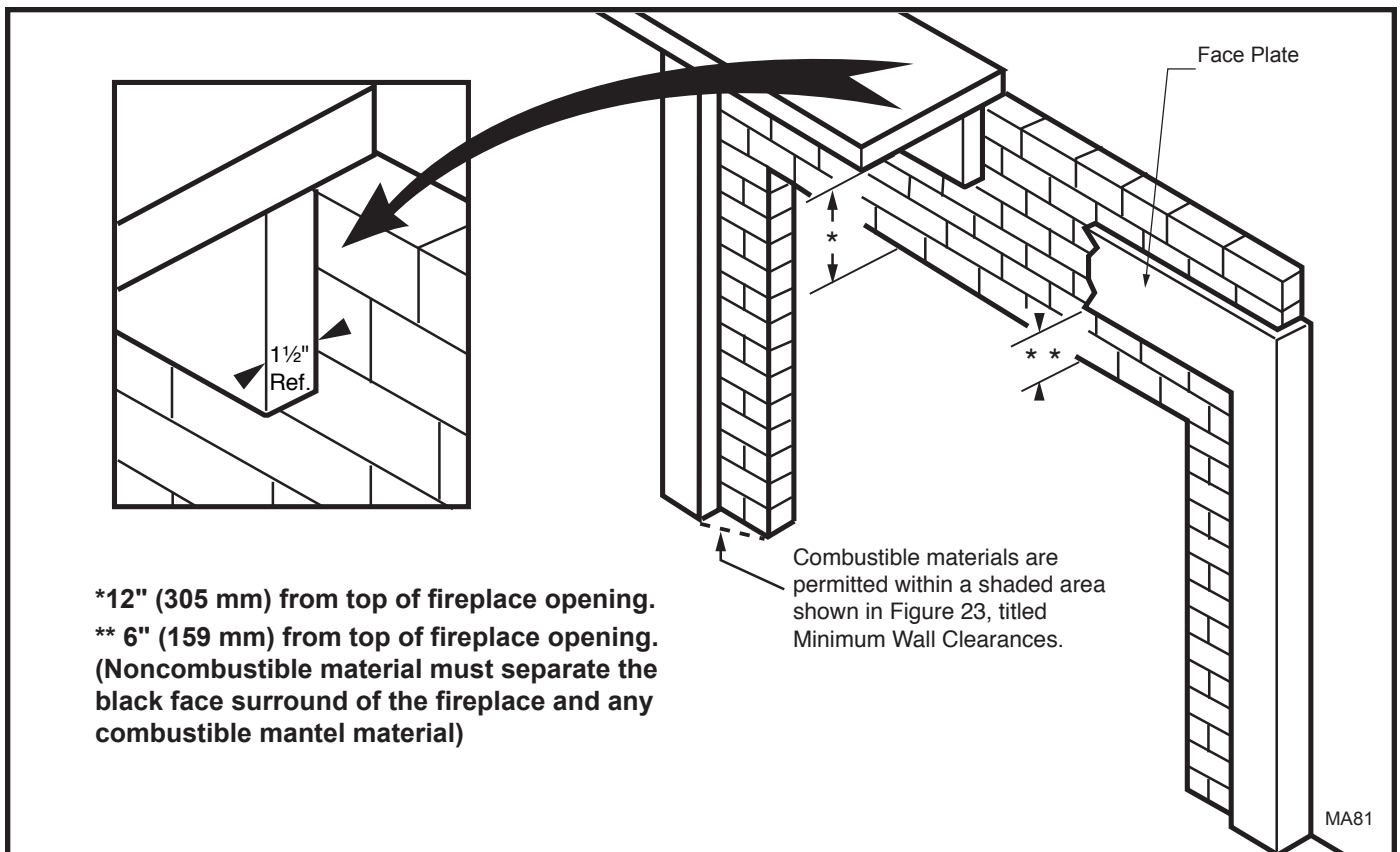

Fig. 22 Combustible mantel clearances.

Side Wall Protection

All joints (top, bottom and sides) where wall or decorative facing material meets fireplace surround must be completely sealed with a noncombustible material. (Figs. 20 and 24)

The special wall shield design described in Figure 20 is an alternate method of adding protection to side walls and can be used in place of the SP40 with the same wall clearances specified for the SP40. Rt must =1.85 minimum.

Examples of wall shield insulation:

1. Manville - CERAFORM 126, K=.27, 1/2 inches thick
2. MHSC - EH2416, K = .458, 1 inch thick required.

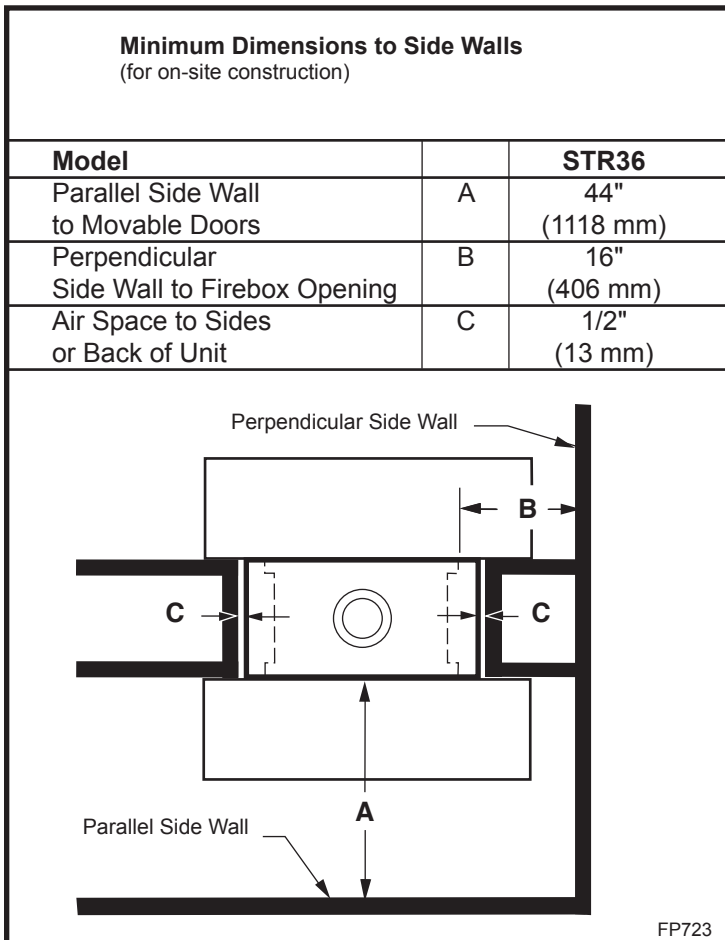

Fig. 23 Minimum firebox dimensions from combustible materials.

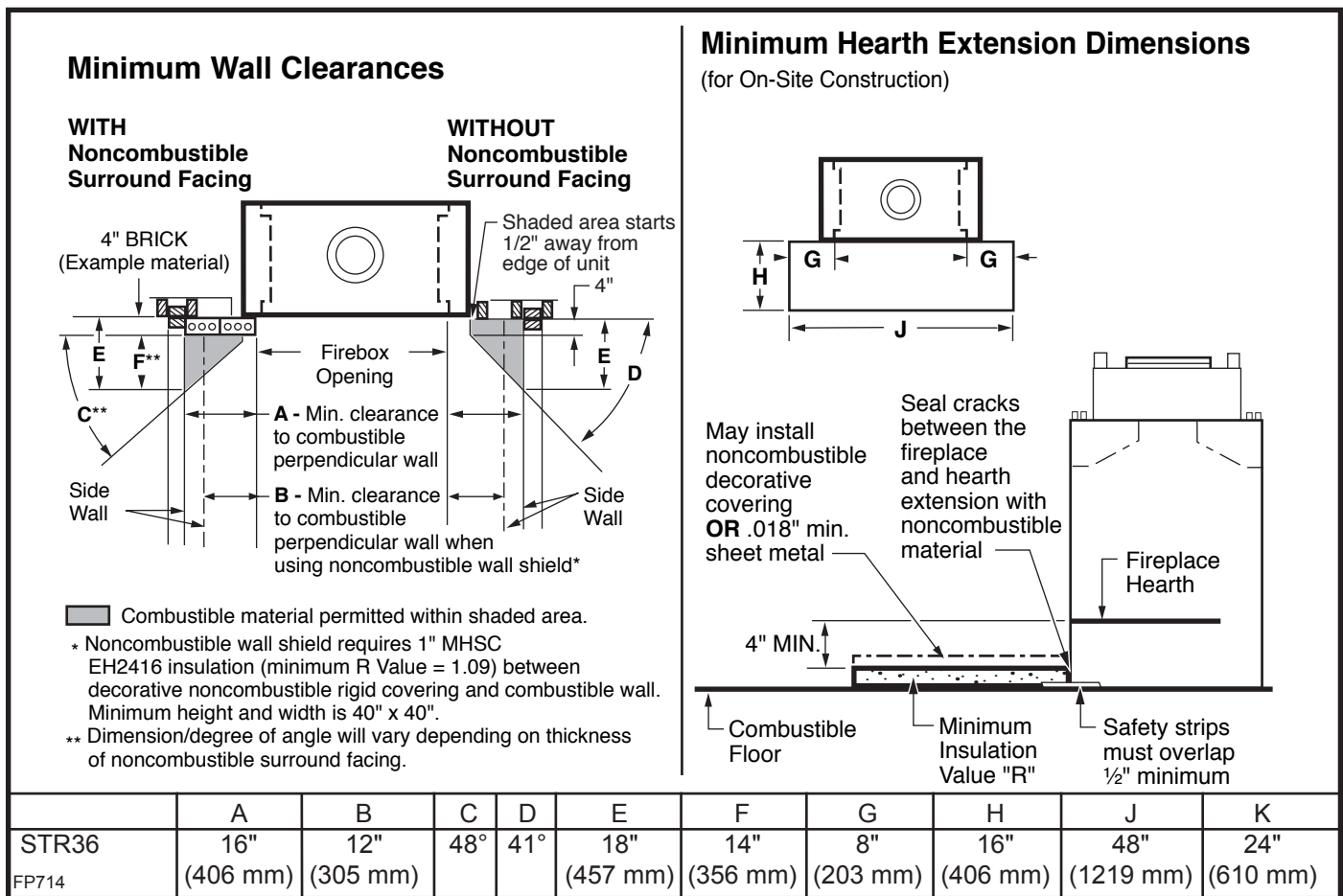

Fig. 24 Combustible side wall protection and hearth extension dimensions.

Hearth Installation

A hearth extension is required to protect a combustible floor in front of the fireplace. Refer to Figure 24 for minimum dimensions and mounting detail.

Note: Hearth Extension must not cover the air inlet opening of a fireplace.

The hearth extension described in Figure 24 must be a durable noncombustible material with a minimum (total) Rt value of 1.09; refer to Figure 25 for examples. The overall height (above a combustible floor), depth and width must be as indicated, with the extension centered to the fireplace opening.

The top of the insulation material must be covered with a noncombustible decorative covering or a piece of .018" minimum sheet metal, to protect hearth extension material. (Fig. 24)

Secure the hearth extension to the floor to prevent shifting, using trim molding or other similar means at three (3) outer edges. Seal crack between the fireplace hearth and hearth extension with a noncombustible material. (Figs. 24 and 26)

WARNING: HEARTH EXTENSION MUST BE INSTALLED IN ACCORDANCE WITH FIGURES 24 AND 25.

Alternate noncombustible materials may be used providing the (total) thermal resistance (Rt value) of the alternate material employed is greater than or equal to R = 1.09. Thermal resistance (R) or thermal conductivity (K), may be obtained from manufacturer of the material. Factors are related by the formula $K = 1/R$.

T = given thickness

R = thermal resistance for a given thickness (T)

K = thermal conductivity

Noncombustible material with a lower R value may be used, provided thickness of material is sufficiently greater to maintain an equivalent (total) thermal resistance (Rt).

Example of Determining Hearth Extension Equivalents

To determine the thickness required for any **new** material:

$$\text{NEW required thickness} = \frac{\text{K of new material (per inch)} \times \text{thickness of listed material}}{\text{K of listed material (per inch)}} \times \text{thickness of listed material}$$

Example for Common Brick

$T(\text{new}) = 5.0 / 0.458 \times 0.50 \text{ in.} = \mathbf{5.46 \text{ in.}}$ (new required thickness).

COMMON MATERIALS AND FACTORS			
MATERIAL	K*	R	MINIMUM THICKNESS
EH2416 (MHSC)	0.458	1.09	0.50 in.**
Common Brick	5.0	0.10	5.46 in.**

R Value is for 1/2 inch.
 * Units of K = BTU/SQ FT/HR/°F/IN
 ** Thickness of Listed Material

Fig. 25 Hearth extension material factors. FP533AD

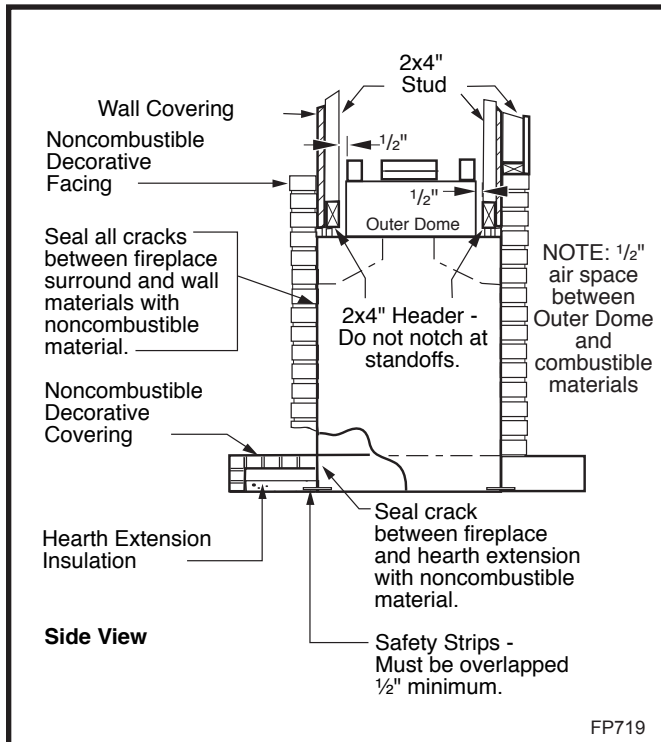

Fig. 26 Finish wall treatments and gap sealing. FP719

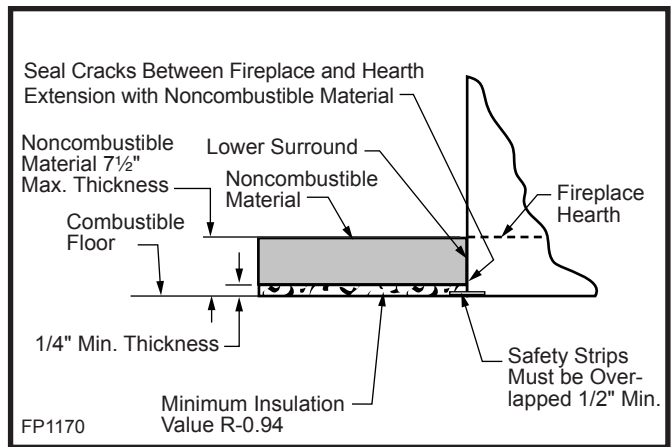

Fig. 27 Hearth extension dimensions.

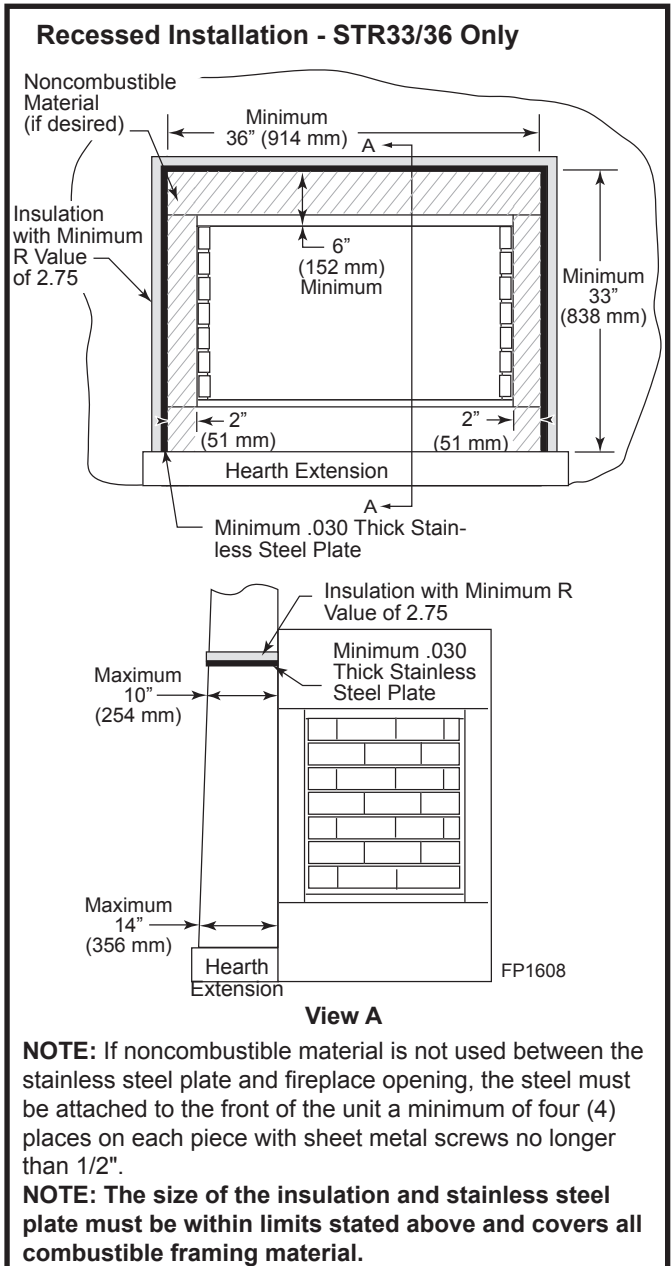

Fig. 28 Recessed installation.

Installing Line for Gas Logs

MHSC are designed to accept a 1/2" (13 mm) gas line for installation of an approved gas appliance. (MHSC manufactures a wide variety of gas logs for use in MHSC fireplaces.)

Be sure to have the appliance installed in accordance with building codes.

Gas connection may enter from either left or right side of the fireplace.

Locate appropriate gas line in the outer casing of fireplace and remove insulation from gas line tube. (Fig. 29)

From inside the fireplace, locate the knockout on the firebrick -- be sure you are on the appropriate or "gas line" side of the fireplace. Using a flat bladed screwdriver or small chisel and hammer, carefully tap around the knockout until it loosens and falls out.

Install 1/2" (13 mm) certified gas pipe through opening. After gas pipe installation is complete, use insulation that was removed from gas line tube to repack space around the pipe. Material should be inserted from outside of the fireplace and packed tightly to totally seal between the pipe and tube.

NOTE: Gas pipe should not come in contact with any wood structures until it has reached a point at least 1" (25 mm) away from fireplace side.

Note: Local codes may require removal of flue damper when installing any type of gas appliance in a fireplace.

NOTE: When installing an ANSI Z21.11.2 ventless appliance, the finishing material used for the mantel must be rated at 250°F or greater.

BTU input of a gas appliance installed in fireplace should be rated less than 100,000 BTU/Hr.

Gas pipe installation is intended for connection to a decorative gas appliance only when (1.) incorporating an automatic shutoff device and (2.) complying with the Standard for Decorative Gas Appliances for Installation in Vented Fireplaces (ANSI Z21.60) or CSA draft requirements for Gas-Fired Log Lighters for Woodburning Fireplaces (Draft No. 4, August 1993).

Decorative gas appliance should be installed in accordance with the National Fuel Gas Code, ANSI Z223.1/ NFPA 54 (latest edition).

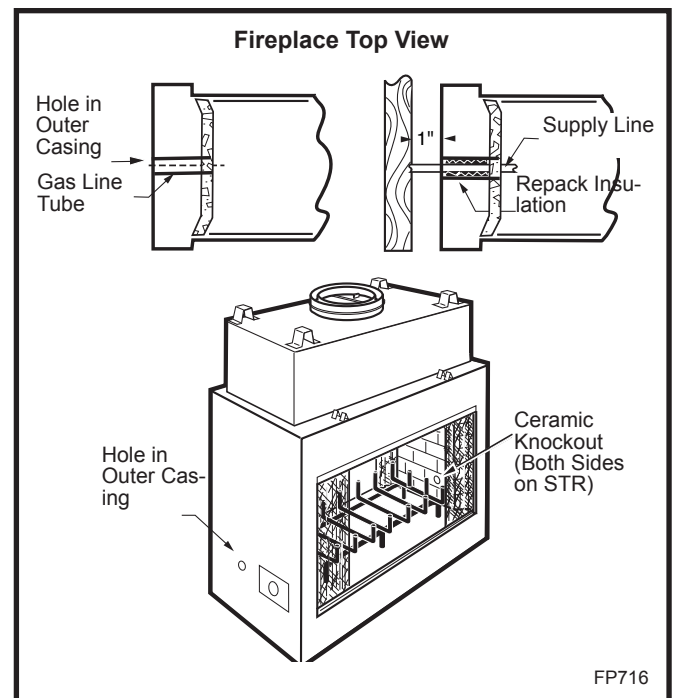

Fig. 29 Gas line access.



CAUTION: WHEN USING DECORATIVE GAS APPLIANCE, FLUE DAMPER MUST BE SET IN FULLY OPEN POSITION. IF YOU HAVE GLASS DOORS ON THE FIREPLACE, THEY MUST ALSO BE FULLY OPENED.



WARNING: DO NOT OPERATE AN UNVENTED GAS LOG SET IN THIS FIREPLACE WITH THE CHIMNEY REMOVED.



WARNING: WHEN INSTALLING AN UNVENTED GAS LOG SET, THE MHSC MODEL CABL OR CABR 4" ADJUSTABLE HOOD MUST BE USED.

If installing an unvented gas log set, refer to statement below:

Only unvented gas log sets which have been found to comply with the Standard for Unvented Room Heaters, ANSI Z21.11.2, are to be installed in this fireplace.

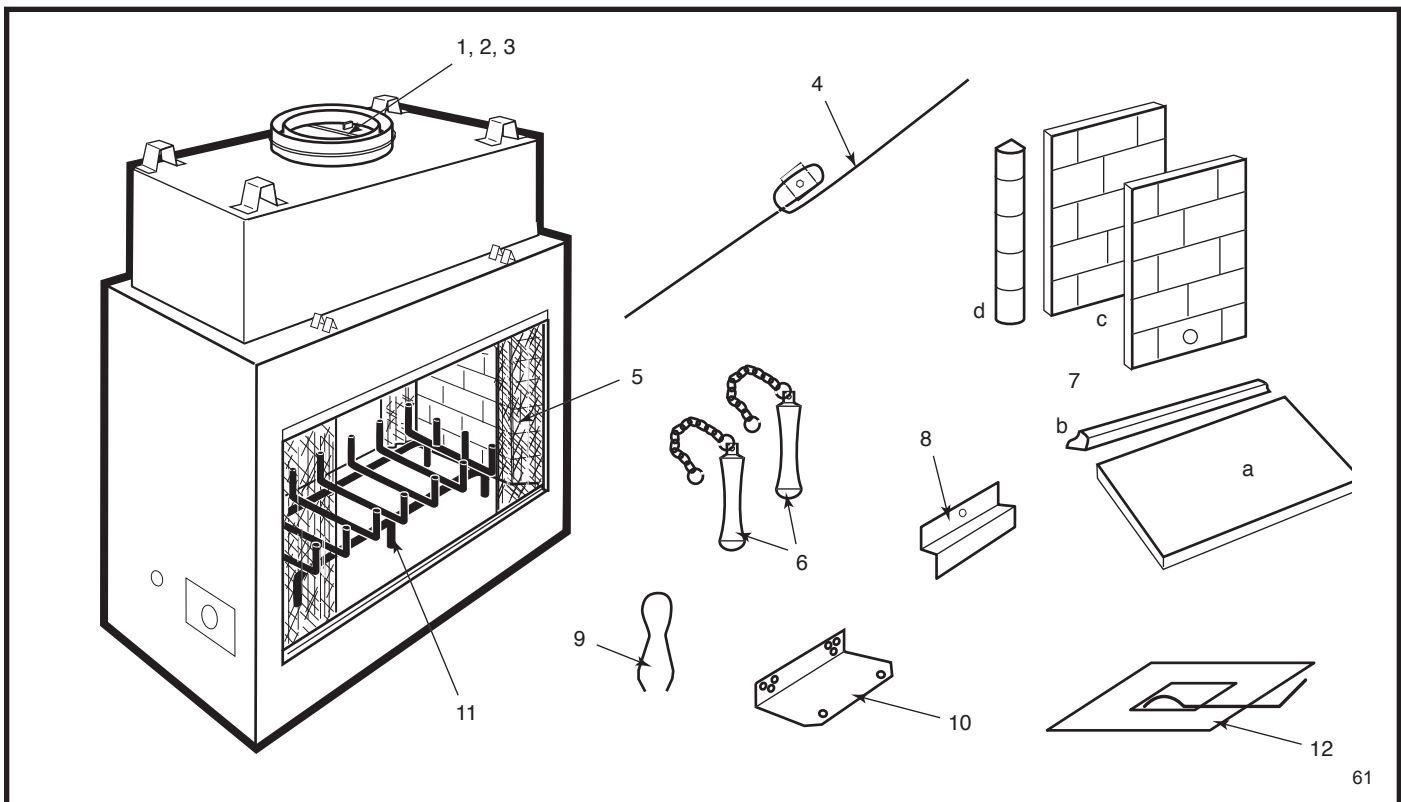

61

MHSC reserves the right to make changes in design, materials, specifications, prices and discontinue colors and products at any time, without notice.

STR36 Woodburning Fireplace

Ref.	Description	STR36
1.	Flue Damper	RP102
2.	Damper Handle	7548170
3.	Damper Handle Push Nut	7512903
4.	Screen Rod Assembly (two per fireplace)	3030126
5.	Screen Assembly (four per fireplace)	7554338
6.	Screen Pulls (four per fireplace)	5584139
7a.	Firebrick - Hearth	3102103
7b.	Firebrick - Side Ashlip (two per fireplace)	3102102
7c.	Firebrick - Side (two per fireplace)	9079147
7d.	Side Filler (four per fireplace)	3079148
8.	Top Brick Retainers (four per fireplace)	3079130
9.	Cable Clips (eight per fireplace)	7512135
10.	Nailing Flange (eight per fireplace)	5069164
11.	Basket Grate	2056100
12.	O.S.A. Assy.	20003212

Accessories

The following accessories for this appliance are available from your local MHSC distributor. Should you need additional information beyond what your distributor can furnish, contact: MHSC, 149 Cleveland Drive, Paris, KY 40361, Attn: Technical Services.

CAUTION: This fireplace and chimney assembly is a highly engineered system, and, as such, must be operated only with MHSC approved components. If you use an unapproved component to make any modifications, you may create a possible fire hazard and will void the MHSC warranty. In addition, such action may void the coverage provided by the owner's insurance.

Accessory	Description		Model Number
Glass Door	Bi-Fold door set	Brushed Brass finish	36GDKBB - STR36
		Black finish	36GDKBK - STR36
		Polished Brass finish	36GDKDP - STR36
		Pewter finish	36GDKS - STR36
Outside Air Termination	Completes connection from air kit to out-of-doors		AK-MST
Hearth Extension Insulation	Provides hearth extension floor protection		EH2416
Basket Grate	Holds firewood in firebox		RBG36ST
Hearth Patch Compound	Patch cracks in hearth		HPC-1

Contact your MHSC distributor or dealer for finishing Marble and Mantels, available in a wide selection of styles.

Chimney Components

U.S.

Component	Description	Model Number
Round Top Termination	Round termination to be used with SK8 chimney system. (Flashing not included.)	RLTSK8
Long Round Top Termination	Round top to be used with a chase installation utilizing SK8 chimney system.	RLTSK8L
Knock-down Shroud - Pyramid	Black pyramid knock-down shroud used for chase installations with any RLT round top termination. Gives appearance of a pyramid cap.	PKDSBL
Knock-down Shroud - Square	Black square knock-down shroud used for chase installations with any RLT round top termination. Gives appearance of a square cap.	SKDSBL Adaptor required
Square Termination	Top housing with simulated brick pattern. (Red, Tan or Black) Proper adapter must be used. Includes flashing.	T20B
Adapter	Required adapters for T20B top housing.	CF8CA (SK8)
Housing Extensions	Extends Square Termination on steep pitched roofs.	202036
Flashing	Metal finishing required around Contemporary Termination to prevent rain leakage.	8-6-12 with 8" flue: 0-6/12 pitch 8-12-12 with 8" flue: 6/12-12/12 pitch
Square Termination	Top housing of simulated brick pattern available in red, tan or white. Appropriate adapter required. Flashing included.	T20B
SK8 Chimney Sections	Pipe used to build 8" SK8 flue systems.	SK81 (1' Long) SK818 (1½' Long) SK83 (3' Long) SK84 (4' Long)
Chimney Elbows	Elbow used to create an offset in a chimney system. Only 30° elbows available. Packaged 2 per carton (offset and return).	SK830 / 2 (SK8)
Firestop	Required at each floor level of chimney installation. (Plus attic on multi-story installation.)	SKFS2A — SK8 (8" straight flue) SKFS6A — SK8 (8" 30° inclined flue)
Chimney Support	Used to support chimney for each of: 20' vertical height and 6' of angled chimney run.	SKCS8 - SK8
Attic Insulation Shield	Used to prevent insulation from coming in contact with the chimney system.	AIS-SK - SK8

Canada

Component	Description	Model Number
Attic Insulation Shield	Used to prevent insulation from coming in contact with the chimney system.	AIS-SK - SK8
SK8 Chimney Sections	Used to build chimney systems exposed above roof.	SK818CAN (1½') SK8 SK84CAN (4') SK8
45° Chimney Elbows	Provides 45° offset and return. FOR CANADIAN INSTALLATIONS ONLY. For use with SK8 chimney only. (Maximum use of 2, or 1pair.)	SK845/2

LIMITED WARRANTY

Factory-Build Fireplace and Components (Except Blowers)

What is Covered and For How Long

Five-Year Coverage: For five years from the date this fireplace and components are first purchased for use, MHSC will, at its option, repair or replace any defective part of this fireplace or components, or refund to you a sum not to exceed the factory retail price in effect at the time of purchase.

Ten-Year Coverage: From the sixth through the tenth year following the date this fireplace or accessory is first purchased for use, MHSC will make available to you, at our factory, a free replacement for any defective part in this fireplace or accessory.

Twenty-Five-Year Availability of Replacement Parts: From the eleventh through the twenty-fifth year following the date this fireplace or accessory is first purchased for use, MHSC will make available at our factory replacement parts for this fireplace or accessory, which you may purchase for the list price current at the time your purchase order is received.

What is Not Covered

- This limited warranty does not cover:
- Transportation or shipping cost.
- The cost of a service call to diagnose trouble.
- Painted surfaces.
- Damage or defect caused by improper installation, accident, misuse, abuse or alteration.
- Poor ventilation of smoke or gases caused by air-conditioning and heating systems, exhaust fans, or pressure differentials produced by wind.
- Broken glass components.
- Cracks in ceramic and castable parts that do not affect safe operation.
- We do not warrant this fireplace to be in compliance with your local building code. Building codes vary greatly throughout the country, and you should determine whether your local building code contains restrictions on the use of this fireplace before you purchase it.
- Blowers or fans, which are warranted separately.
- Heat loss due to the passage of heat or air through or around the fireplace.

Also, under our five year coverage, we do not pay the cost of removal and replacement of any portion of the structure in which the fireplace is situated, made necessary by the repair, removal or re-installation of the fireplace.

And under our twenty-five year warranty of availability of replacement parts, we only promise to maintain a supply of replacement parts at our factory for you to purchase.

Limitations and Exclusions

1. No one has authority to add to or vary this limited warranty, or to create for MHSC any other obligations of liability in connection with this fireplace and accessory.
2. MHSC shall not be liable for incidental, consequential, special or contingent damages you might suffer as a result of its breach of this written warranty or any implied warranty. Some states do not allow the exclusion of limitation of incidental or consequential damages, so the above limitations may not apply to you.
3. This warranty applies only to a fireplace sold and used in the United States.

IF WARRANTY SERVICE IS NEEDED...

1. Contact your supplier. Make sure you have your warranty, your sales receipt and the model/serial number of your MHSC product.
2. DO NOT ATTEMPT TO DO ANY SERVICE WORK YOURSELF.

MHSC

149 Cleveland Drive • Paris, Kentucky 40361
www.mhsc.com