

PRODUCT SPECIFICATIONS  
**SS38DV Direct Vent Gas Stove**



**INTERIOR DIMENSIONS**

Front opening width: 26-1/2"  
Front opening height: 31-1/2"  
Firebox depth: 17"

**TECHNICAL INFORMATION**

Shipping Weight (Lbs): 170  
Heating Capacity (Sq. Ft.): 1,800  
Fire Viewing Area (Sp. inch): 316  
Flue Size: 4" x 6-5/8"  
Fan: 160 cfm  
BTU/hr Input Rate (NG): 27,000-38,000  
BTU/hr Input Rate (LP): 25,000-35,000  
Thermal Efficiency (%): Up to 80  
P4 EnerGuide Rating: NG: 80.1% LP: 81.8%  
Clearances: Back: 6" Side: 9" Corner: 6"  
CSA Design Certified

**FIELD INSTALLED ACCESSORIES**

High Altitude Kit (NG): (SS38HAKN)  
High Altitude Kit (LP): (SS38HAKP)  
Conversion Kits Available

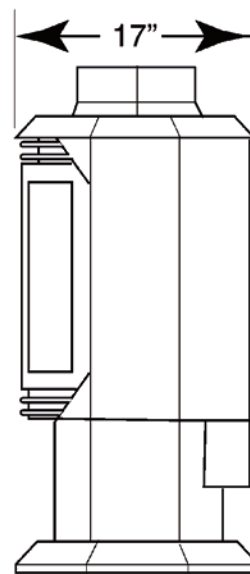
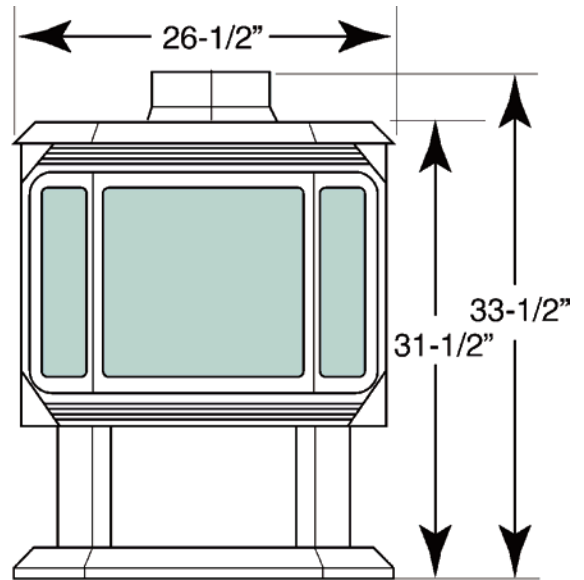

A Brand of Monessen Hearth Systems Co.  
149 Cleveland Drive, Paris, Kentucky 40361  
[www.majesticproducts.com](http://www.majesticproducts.com)



To avoid personal injury or property damage, the product described by this brochure must be installed, operated and maintained in strict compliance with the instructions packaged with the product and all applicable building or fire codes. Contact local building or fire officials about restrictions and installation inspection requirements. All photographs and drawings on this brochure are for illustrative purposes only and are not intended for, nor should they be used as a substitute for the instructions packaged with the unit. Appearance and specifications of the product are subject to change without notice. 02/10 Ver. 2